

Theorie van Concurrency

najaar 2011

<http://www.liacs.nl/home/rvvliet/tvc/>

vijftiende college: donderdag 1 december 2011
(laatste hoorcollege)

- 9. P/T Systems
- 9.5. Place Invariants
- 9.6. Marked Graphs
- 9.7. Free-Choice Systems

zesde en laatste werkcollege: donderdag 8 december 2011

9.5. Place Invariants

Definition 188. Let $M = (P, T, F, W, C_{in})$ be a P/T system.

A vector $i : P \rightarrow \mathbb{Z}$ is a *place invariant* (*p-invariant*) of M if for all configurations $C, D : P \rightarrow \mathbb{N}$ and all $t \in T$: if $C[t]D$, then $C \cdot i = D \cdot i$. The *value* of i is the integer $C_{in} \cdot i$.

A p-invariant $i : P \rightarrow \mathbb{N}$ is a *positive* p-invariant of M .

A p-invariant $i : P \rightarrow \{0, 1\}$ is a *characteristic* p-invariant of M

A characteristic p-invariant with value 1 is a *sequential component* of M .

Lemma 189. Let $M = (P, T, F, W, C_{in})$ be a P/T system and let $i : P \rightarrow \mathbb{Z}$ be a p-invariant of M .

Then $C \cdot i = C_{in} \cdot i$ for all $C \in \mathbb{C}_M$.

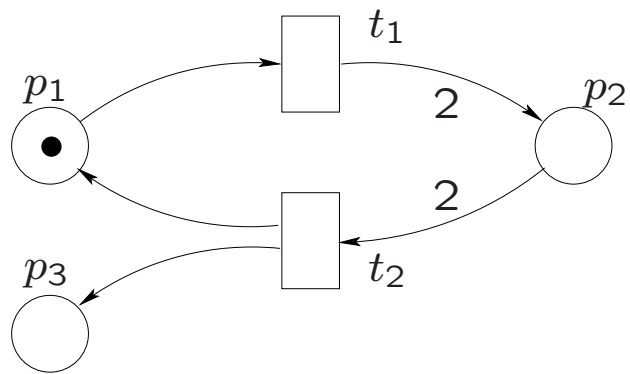

Fig. 90. P/T system M'' with invariant $2C(p_1) + C(p_2) = 2$.

Definition 190. Let $M = (P, T, F, W, C_{in})$ be a P/T system.

(1) For every transition $t \in T$ the vector $\underline{t} : P \rightarrow \mathbb{Z}$ is defined as follows:

for every $p \in P$,

$$\begin{aligned} \underline{t}(p) &= W(t, p) && \text{if } p \in t^\bullet, \\ \underline{t}(p) &= -W(p, t) && \text{if } p \in {}^\bullet t, \text{ and} \\ \underline{t}(p) &= 0 && \text{otherwise.} \end{aligned}$$

(2) The matrix $\underline{M} : T \times P \rightarrow \mathbb{Z}$ is defined by
for every $t \in T$ and every $p \in P$, $\underline{M}(t, p) = \underline{t}(p)$.

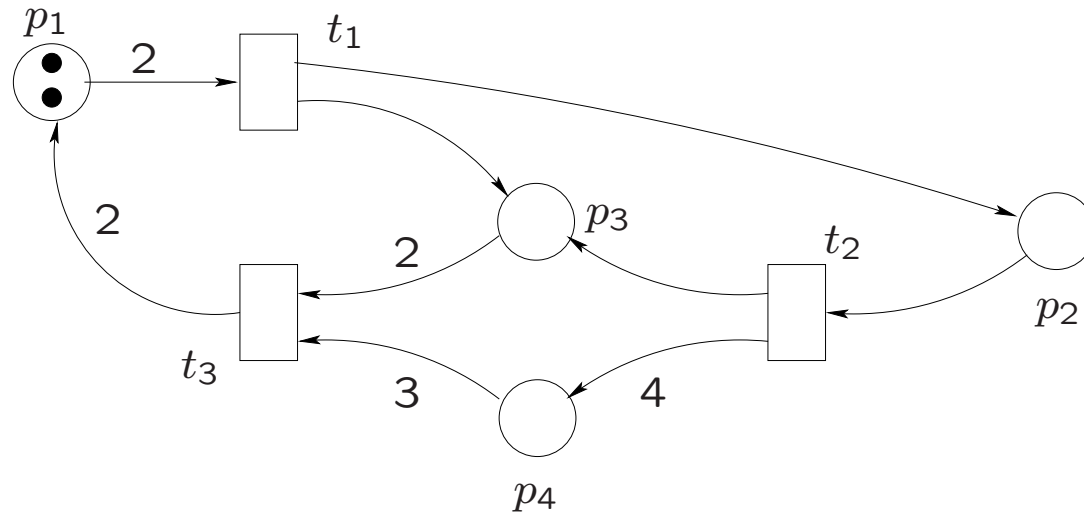

Fig. 92. A P/T system M to illustrate linear algebra.

$$\underline{M} = \begin{array}{c} t_1 \\ t_2 \\ t_3 \end{array} \begin{pmatrix} p_1 & p_2 & p_3 & p_4 \\ -2 & +1 & +1 & 0 \\ 0 & -1 & +1 & +4 \\ +2 & 0 & -2 & -3 \end{pmatrix}$$

Lemma 191. Let M be a P/T system, let C and D be two configurations of M , and let $t \in T_M$.
Then $C[t\rangle D$ iff $D = C + \underline{t}$.

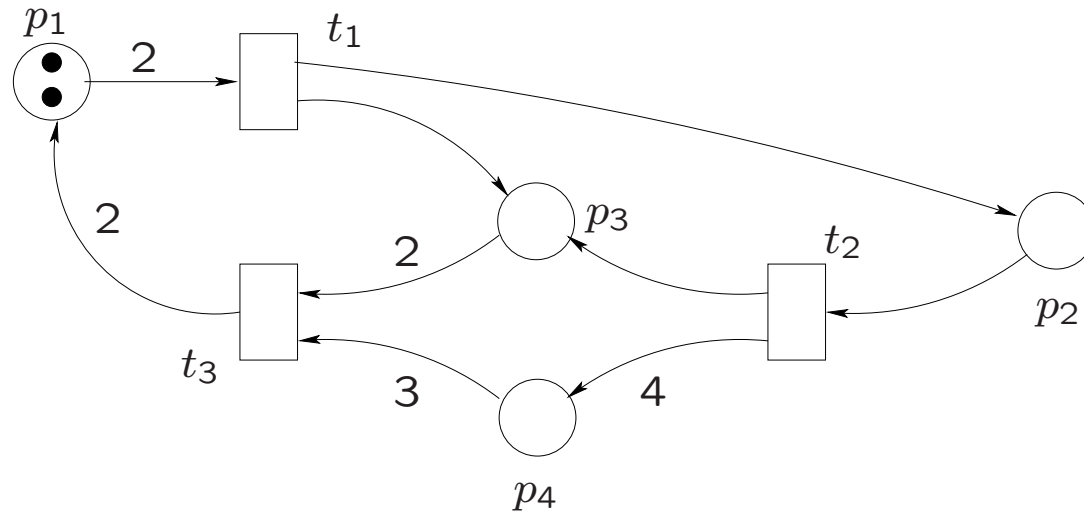

Fig. 92. A P/T system M to illustrate linear algebra.

	C_{in}	$[t_1\rangle$	C_1	$[t_2\rangle$	C_2	$[t_3\rangle$	C_3	$[t_1\rangle$	C_4	$[t_2\rangle$	C_5	$[t_3\rangle$	C_6
p_1	(2)	-2	(0)	0	(0)	+2	(2)	-2	(0)	0	(0)	+2	(2)
p_2	(0)	+1	(1)	-1	(0)	0	(0)	+1	(1)	-1	(0)	0	(0)
p_3	(0)	+1	(1)	+1	(2)	-2	(0)	+1	(1)	+1	(2)	-2	(0)
p_4	(0)	0	(0)	+4	(4)	-3	(1)	0	(1)	+4	(5)	-3	(2)

$$\underline{M} = \begin{matrix} & & p_1 & p_2 & p_3 & p_4 \\ \begin{matrix} t_1 \\ t_2 \\ t_3 \end{matrix} & \left(\begin{array}{cccc} -2 & +1 & +1 & 0 \\ 0 & -1 & +1 & +4 \\ +2 & 0 & -2 & -3 \end{array} \right) \end{matrix}$$

	C_{in}	$[t_1\rangle$	C_1	$[t_2\rangle$	C_2	$[t_3\rangle$	C_3	$[t_1\rangle$	C_4	$[t_2\rangle$	C_5	$[t_3\rangle$	C_6
p_1	(2)	-2	(0)	0	(0)	+2	(2)	-2	(0)	0	(0)	+2	(2)
p_2	(0)	+1	(1)	-1	(0)	0	(0)	+1	(1)	-1	(0)	0	(0)
p_3	(0)	+1	(1)	+1	(2)	-2	(0)	+1	(1)	+1	(2)	-2	(0)
p_4	(0)	0	(0)	+4	(4)	-3	(1)	0	(1)	+4	(5)	-3	(2)

Theorem 192. Let $M = (P, T, F, W, C_{in})$ be a P/T system and let $i : P \rightarrow \mathbb{Z}$. Then the following three statements are equivalent.

- (1) i is a p-invariant;
- (2) $\underline{t} \cdot i = 0$ for all $t \in T$;
- (3) $\underline{M} \cdot i = 0$.

If, moreover, M is reduced, then this is also equivalent with

- (4) $C \cdot i = C_{in} \cdot i$ for all $C \in \mathbb{C}_M$.

Corollary 193. Let $M = (P, T, F, W, C_{in})$ be a P/T system and let $i : P \rightarrow \mathbb{N}$ be the characteristic function of $S \subseteq P$.

Then i is a (characteristic) p-invariant iff

$$\sum\{W(p, t) \mid p \in \bullet t \cap S\} = \sum\{W(t, p) \mid p \in t \bullet \cap S\} \text{ for all } t \in T.$$

If, in particular, $W(x, y) = 1$ for all $(x, y) \in F$, then this is equivalent with: $\#(\bullet t \cap S) = \#(t \bullet \cap S)$ for all $t \in T$.

Theorem 49. Let $M = (P, T, F, C_{in})$ be a **reduced** EN system and let $S \subseteq P$.

Then the following statements are equivalent.

(1) There is a sequential component M' of M with $P_{M'} = S$,

(2) $\#(C \cap S) = 1$ for all $C \in \mathbb{C}_M$,

(3) (i) $\#(C_{in} \cap S) = 1$, and

(ii) $\forall t \in T :$

$\#(\bullet t \cap S) = \#(t \bullet \cap S) = 1$ or $\#(\bullet t \cap S) = \#(t \bullet \cap S) = 0$.

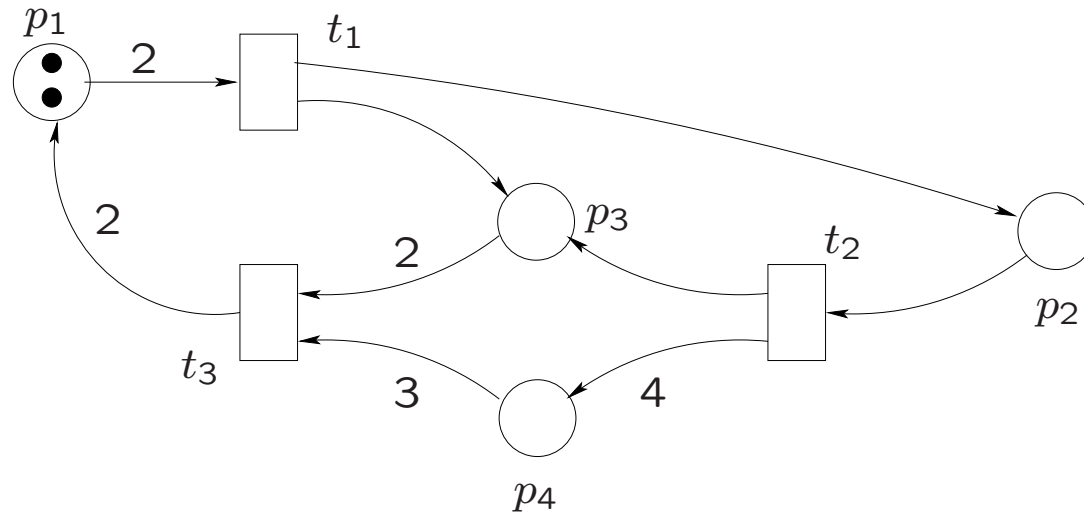

Fig. 92. A P/T system M to illustrate linear algebra.

$$\underline{M} = \begin{array}{c} t_1 \\ t_2 \\ t_3 \end{array} \begin{pmatrix} p_1 & p_2 & p_3 & p_4 \\ -2 & +1 & +1 & 0 \\ 0 & -1 & +1 & +4 \\ +2 & 0 & -2 & -3 \end{pmatrix}$$

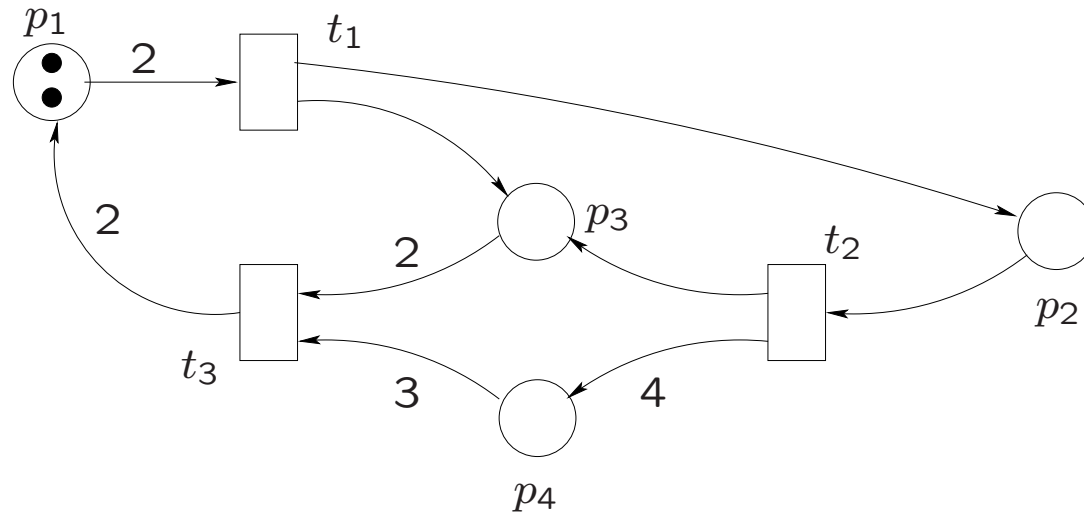

Fig. 92. A P/T system M to illustrate linear algebra.

$$\underline{M} \cdot i = \begin{array}{c} t_1 \\ t_2 \\ t_3 \end{array} \begin{array}{c} p_1 \quad p_2 \quad p_3 \quad p_4 \\ \left(\begin{array}{cccc} -2 & +1 & +1 & 0 \\ 0 & -1 & +1 & +4 \\ +2 & 0 & -2 & -3 \end{array} \right) \end{array} \cdot \begin{array}{c} \left(\begin{array}{c} 1 \\ 1 \\ 1 \\ 0 \end{array} \right) \end{array} = \begin{array}{c} \left(\begin{array}{c} 0 \\ 0 \\ 0 \end{array} \right) \end{array}$$

Lemma 194. Let M be a P/T system and let $\lambda \in \mathbb{Z}$.

If i_1 and i_2 are p-invariants of M , then so are $i_1 + i_2$ and $\lambda \cdot i_1$.

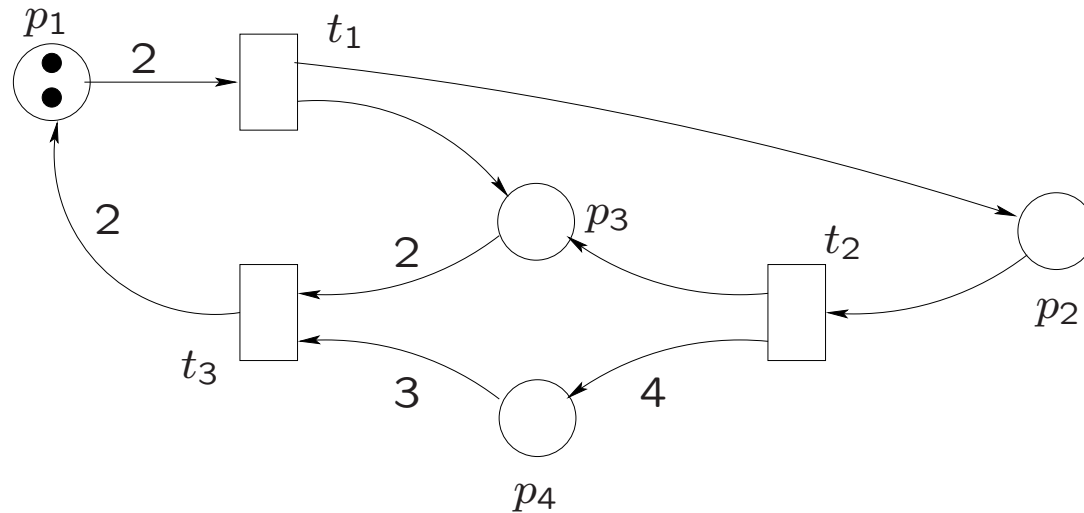

Fig. 92. A P/T system M to illustrate linear algebra.

$$\underline{M} \cdot i = \begin{matrix} t_1 \\ t_2 \\ t_3 \end{matrix} \begin{pmatrix} p_1 & p_2 & p_3 & p_4 \\ -2 & +1 & +1 & 0 \\ 0 & -1 & +1 & +4 \\ +2 & 0 & -2 & -3 \end{pmatrix} \cdot \begin{pmatrix} x_1 \\ x_2 \\ x_3 \\ x_4 \end{pmatrix} = \begin{pmatrix} 0 \\ 0 \\ 0 \end{pmatrix}$$

$$\underline{M \cdot i} = \begin{matrix} t_1 \\ t_2 \\ t_3 \end{matrix} \begin{matrix} p_1 & p_2 & p_3 & p_4 \\ \begin{pmatrix} -2 & +1 & +1 & 0 \\ 0 & -1 & +1 & +4 \\ +2 & 0 & -2 & -3 \end{pmatrix} \end{matrix} \cdot \begin{pmatrix} x_1 \\ x_2 \\ x_3 \\ x_4 \end{pmatrix} = \begin{pmatrix} 0 \\ 0 \\ 0 \end{pmatrix}$$

In other words:

$$\begin{aligned} -2x_1 + x_2 + x_3 &= 0, \\ -x_2 + x_3 + 4x_4 &= 0, \\ +2x_1 - 2x_3 - 3x_4 &= 0. \end{aligned}$$

Only solutions: $(x_1, x_2, x_3, x_4) = \lambda \cdot (1, 1, 1, 0)$ with $\lambda \in \mathbb{Z}$

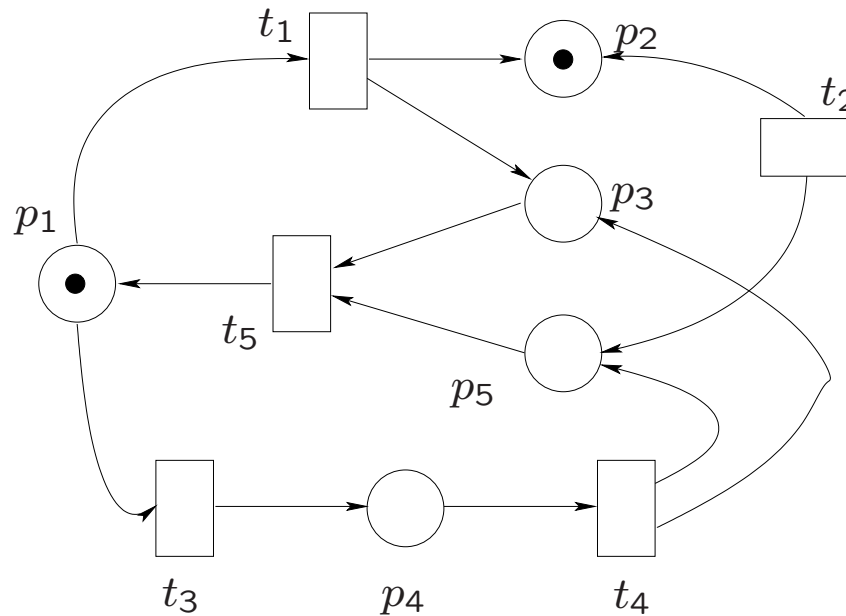

Fig. 93. p-invariants $\lambda \cdot (1, 1, 0, 1, 1) + \mu \cdot (1, 0, 1, 1, 0)$.

Its p-invariants are the solutions $i = (x_1, x_2, x_3, x_4, x_5)$ of:

$$\begin{array}{rcccccc}
 -x_1 & + & x_2 & + & x_3 & & = & 0 & , \\
 & & - & x_2 & & & + & x_5 & = & 0 & , \\
 -x_1 & & & & & + & x_4 & & = & 0 & , \\
 & & + & x_3 & - & x_4 & + & x_5 & = & 0 & , \\
 +x_1 & & - & x_3 & & & - & x_5 & = & 0 & .
 \end{array}$$

Lemma 195. Let M be a P/T system and let i be a positive p-invariant of M .

For $S = \{p \in P_M \mid i(p) > 0\}$, $\bullet S = S^\bullet$.

Lemma 47. Let $M = (P, T, F, C_{in})$ be an EN system and let $S \subseteq P$.

There exists a subsystem M' of M with $P_{M'} = S$ iff $\bullet S = S^\bullet$.

Theorem 196. Let M be a P/T system and let i be a positive p-invariant of M .

For all $p \in P_M$, if $i(p) > 0$, then p is bounded.

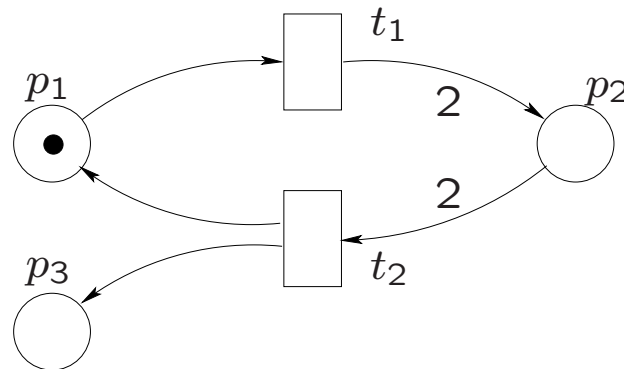
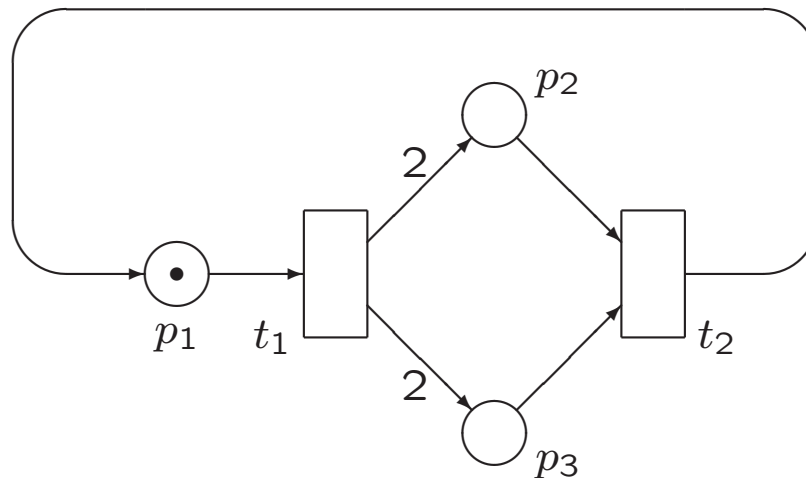

Fig. 90. P/T system M'' with invariant $2C(p_1) + C(p_2) = 2$.

Theorem 196. Let M be a P/T system and let i be a positive p-invariant of M .

For all $p \in P_M$, if $i(p) > 0$, then p is bounded.

If i is not a positive invariant, then the claim is not necessarily true:



$$i = (0, 1, -1) \text{ or } i = (0, -1, 1)$$

Definition 197. Let $M = (P, T, F, W, C_{in})$ be a P/T system.

A collection $\{i_1, \dots, i_n\}$ of positive p-invariants of M is a *covering* of M if

for every place $p \in P$ there exists k , $1 \leq k \leq n$, with $i_k(p) > 0$.

Then M is *covered* by $\{i_1, \dots, i_n\}$.

Lemma 195. Let M be a P/T system and let i be a positive p-invariant of M .

For $S = \{p \in P_M \mid i(p) > 0\}$, $\bullet S = S^\bullet$.

Lemma 53. Let $M = (P, T, F, C_{in})$ be an EN system, and let, for every $1 \leq i \leq n$ (with $n \geq 0$), $M_i = (S_i, T_i, F_i, (C_{in})_i)$ be a subsystem of M .

Then $\{M_1, \dots, M_n\}$ is a covering of M
iff $P = \bigcup_{i=1}^n S_i$.

Theorem 198. If a P/T system M is covered by positive p-invariants, then M is bounded.

Lemma 199. A P/T system M is covered by positive p-invariants iff there exists a p-invariant i of M such that $i(p) > 0$ for all $p \in P_M$.

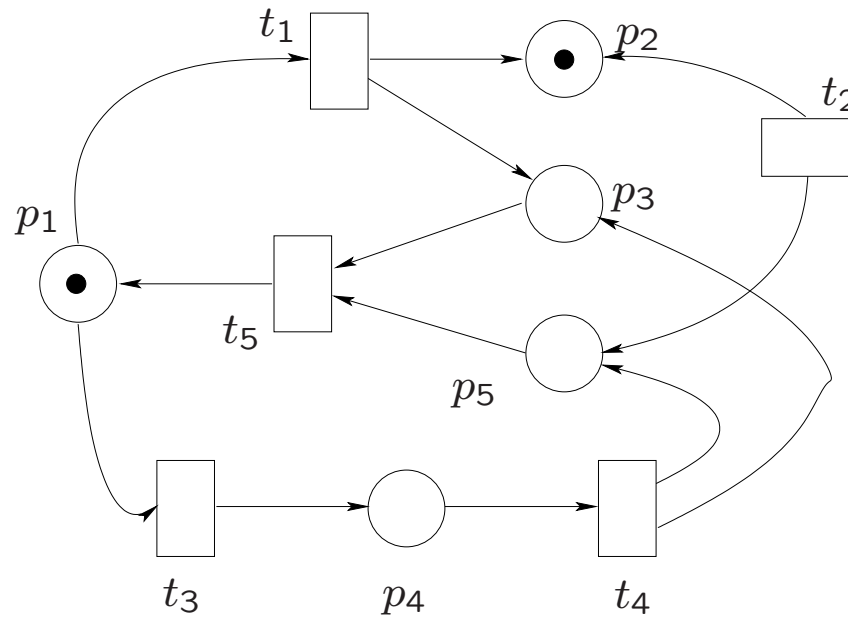

Fig. 93. p-invariants $\lambda \cdot (1, 1, 0, 1, 1) + \mu \cdot (1, 0, 1, 1, 0)$.

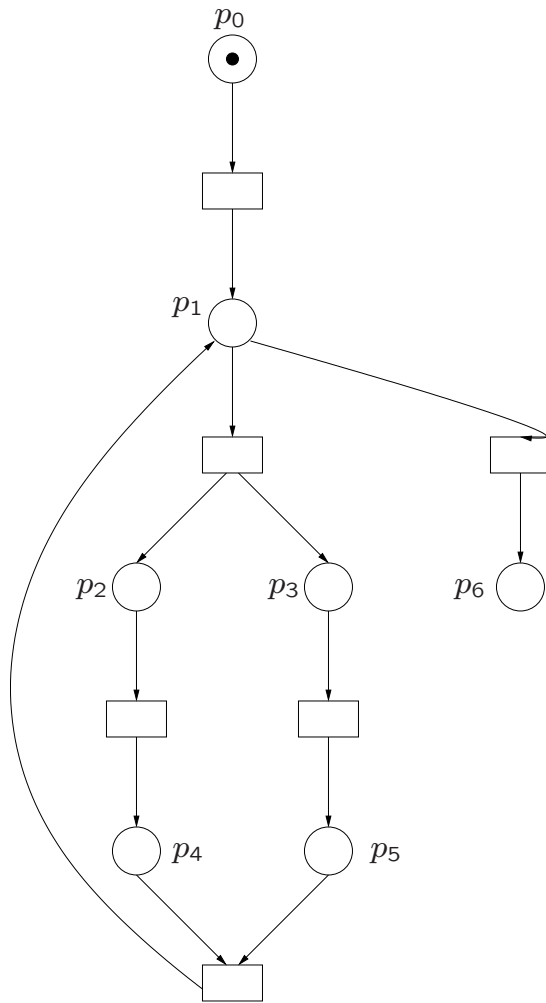

Fig. 15. A (contact-free) EN system, covered by sequential components $\{p_0, p_1, p_2, p_4, p_6\}$ and $\{p_0, p_1, p_3, p_5, p_6\}$.

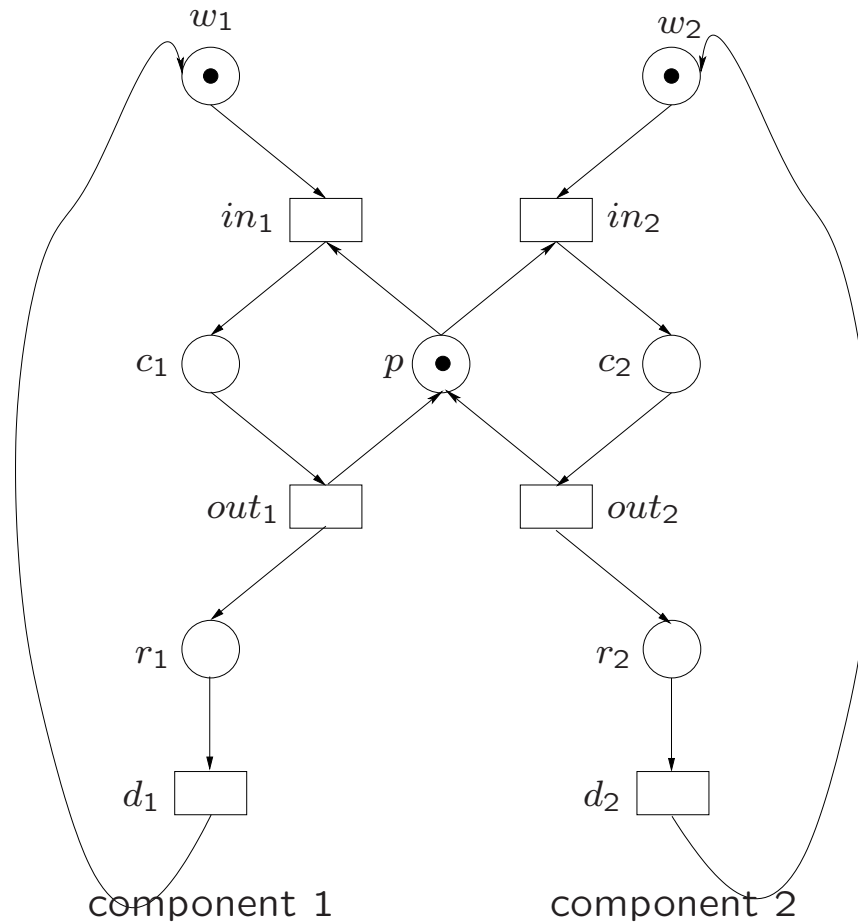

Fig. 5. The mutual exclusion problem.

A contact-free EN system, covered by sequential components $\{w_1, c_1, r_1\}$, $\{w_2, c_2, r_2\}$ and $\{p, c_1, c_2\}$.

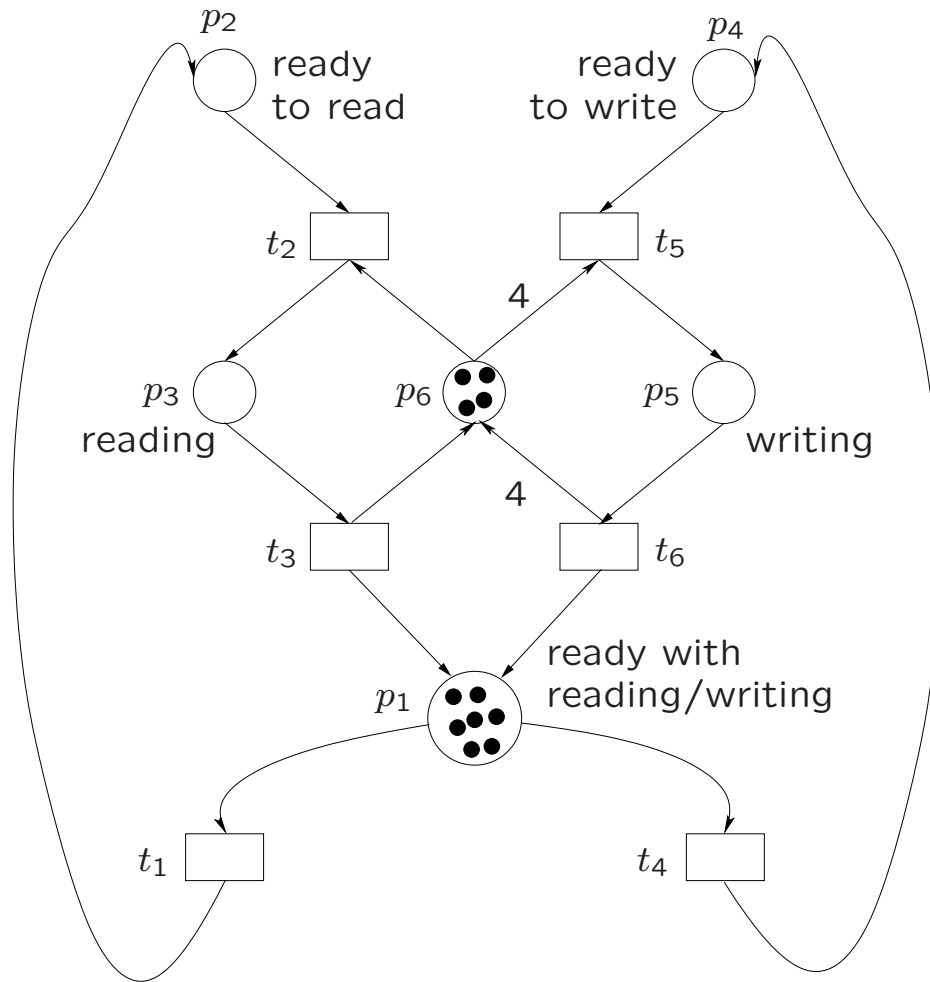

Fig. 94. An application: readers and writers.

Definition 200. A P/T system M is *live* if all transitions of M are live.

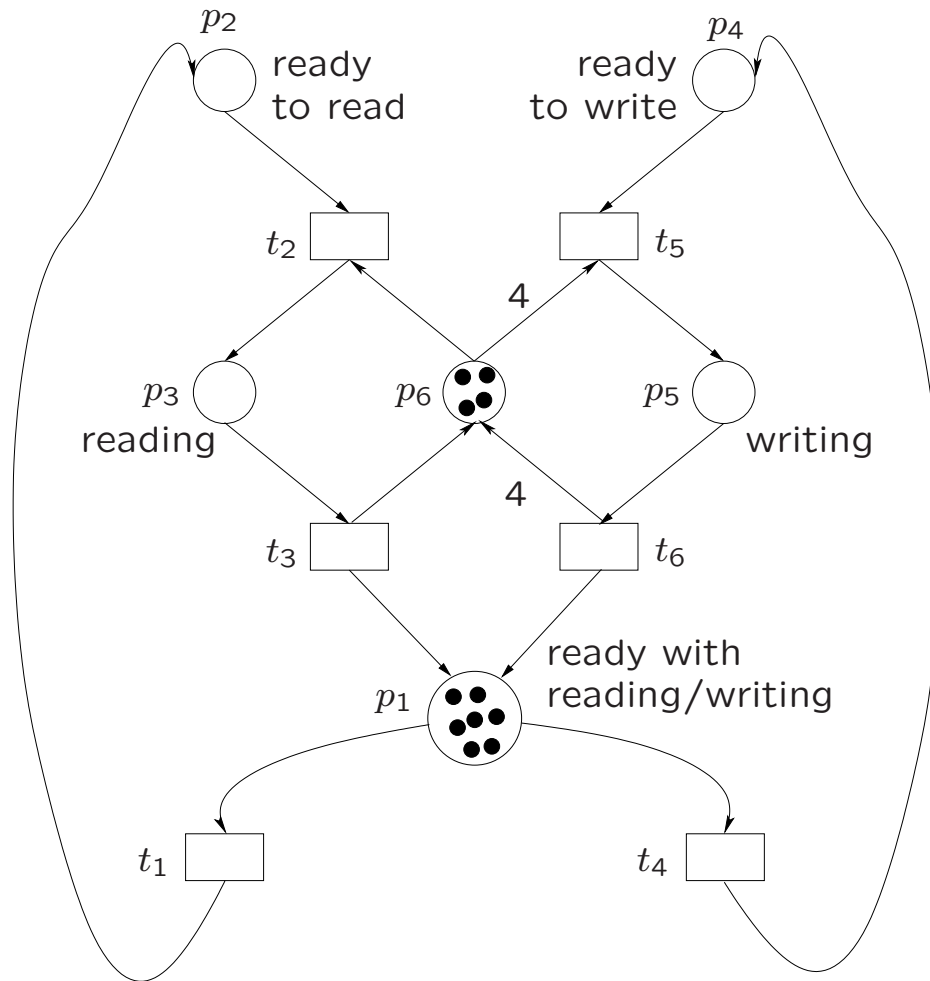

Fig. 94. Readers and writers, with the two p-invariants $i_1 = (1, 1, 1, 1, 1, 0)$ and $i_2 = (0, 0, 1, 0, 4, 1)$.

9.6. Marked Graphs

Definition 201. A *marked graph* (or *T-system*) is a P/T system $M = (P, T, F, W, C_{in})$, where

(1) $W(x, y) = 1$ for all $(x, y) \in F$, and

(2) $\#(\bullet p) = \#(p\bullet) = 1$ for all $p \in P$.

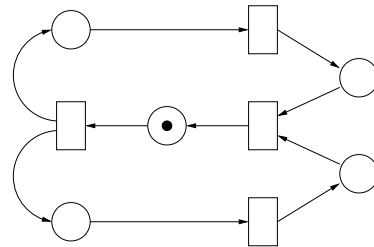

Fig. 95. A marked graph.

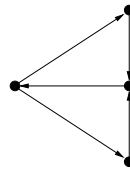

Fig. 96. The corresponding graph (without tokens).

Definition 202. Let $M = (P, T, F, W, C_{in})$ be a **marked graph**.

(1) A sequence $\alpha = (p_0, p_1, \dots, p_m)$ of places is a *path of M from p_0 to p_m* , if

$p_i^\bullet = \bullet p_{i+1}$ for every $0 \leq i \leq m - 1$.

If $p_m^\bullet = \bullet p_0$ and all p_i^\bullet , $0 \leq i \leq m$, are different, then α is a (*elementary*) *cycle of M* ;

$t \in T$ is *on α* if $t = p_i^\bullet$ for some p_i .

(2) $C(\alpha) = \sum_{i=0}^m C(p_i)$ is the *value of α in C* .

If $C(\alpha) > 0$, then α is *marked by C* .

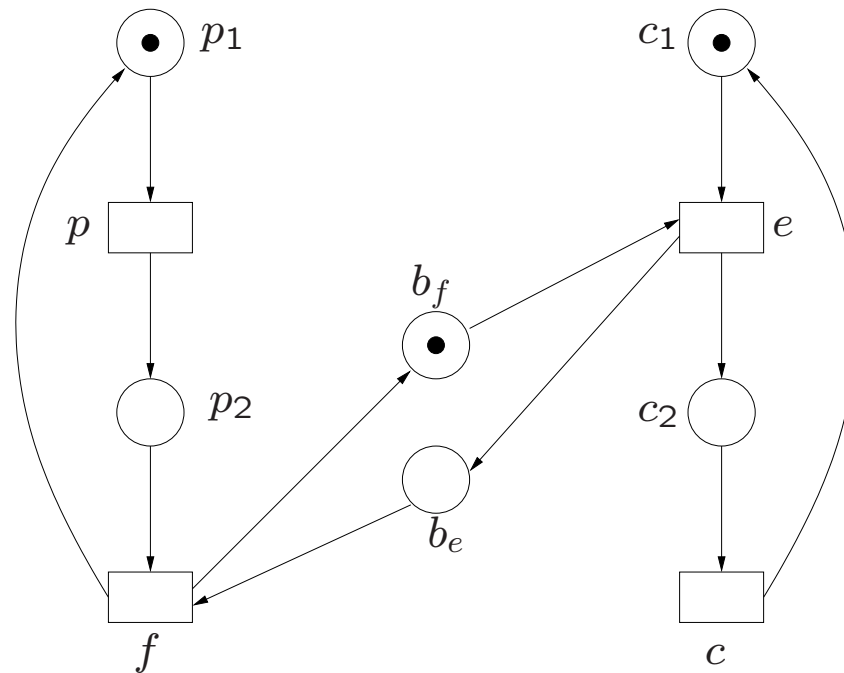

Fig. 49. The result of complementing $b = b_f$ in the producer/consumer system of Fig. 12. A marked graph with three cycles.

Lemma 203. Let $M = (P, T, F, W, C_{in})$ be a marked graph. Let $\alpha = (p_0, \dots, p_m)$ be a cycle of M and let C_α be the characteristic function of $\{p_0, \dots, p_m\}$. Then

(1) C_α is a characteristic p-invariant of M , and

(2) $C(\alpha) = C_{in}(\alpha)$ for all $C \in \mathbb{C}_M$.

Corollary 193. Let $M = (P, T, F, W, C_{in})$ be a P/T system and let $i : P \rightarrow \mathbb{N}$ be the characteristic function of $S \subseteq P$.

Then i is a (characteristic) p-invariant iff

$$\sum\{W(p, t) \mid p \in \bullet t \cap S\} = \sum\{W(t, p) \mid p \in t \bullet \cap S\} \text{ for all } t \in T.$$

If, in particular, $W(x, y) = 1$ for all $(x, y) \in F$, then this is equivalent with: $\#(\bullet t \cap S) = \#(t \bullet \cap S)$ for all $t \in T$.

Theorem 204. Let $M = (P, T, F, W, C_{in})$ be a marked graph.
Then

(1) M is live,

iff

(2) M is (strongly!) reduced,

iff

(3) all cycles of M have a value > 0 .

The proof of the implication $(3) \Rightarrow (1)$ does not have to be known
for the exam

Theorem 205. Let M be a reduced marked graph. Then

(1) M is safe,

iff

(2) M is covered by sequential components,

iff

(3) every place of M belongs to a cycle of M with value 1.

Corollary 206. A marked graph M is live and safe iff every cycle of M is marked by $(C_{in})_M$ and every place of M belongs to at least one cycle with value 1 in $(C_{in})_M$.

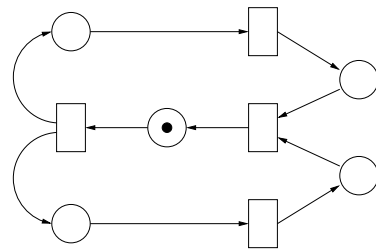

Fig. 95. A marked graph: live and safe.

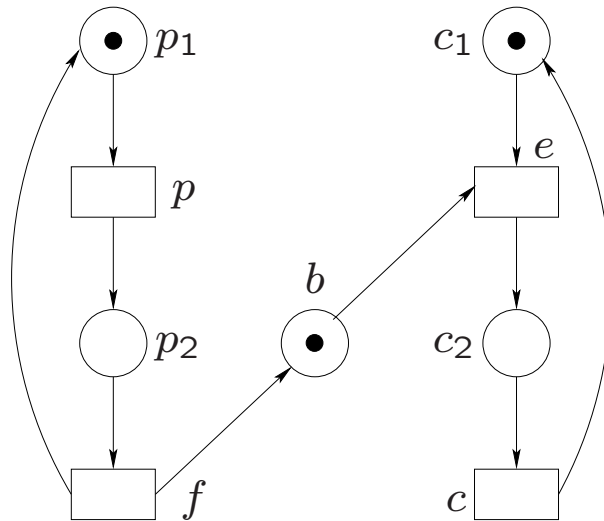

Fig. 12. The producer/consumer problem (to be considered as a marked graph): live and not safe.

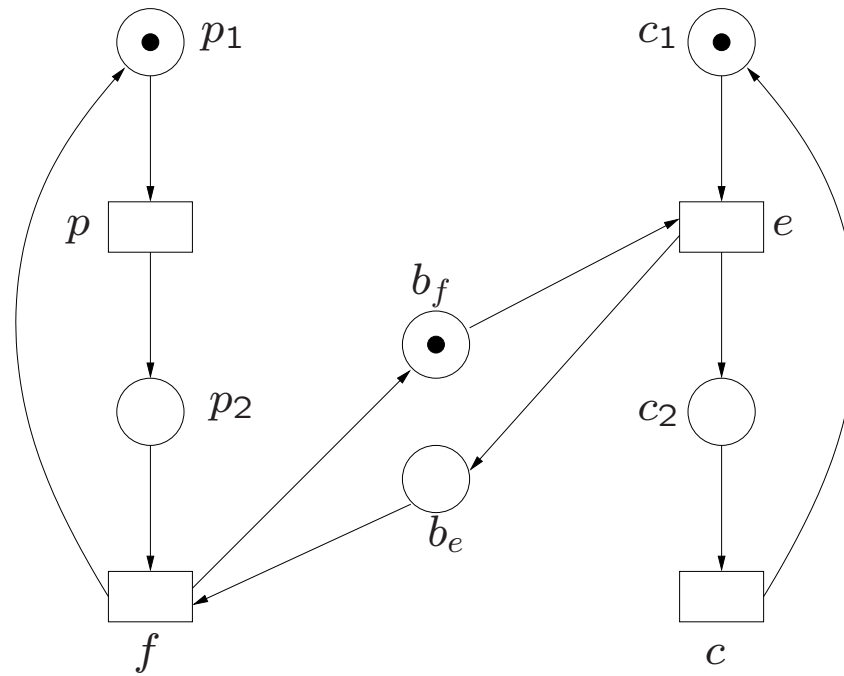

Fig. 49. The result of complementing $b = b_f$ in the producer/consumer system of Fig. 12: live and safe.

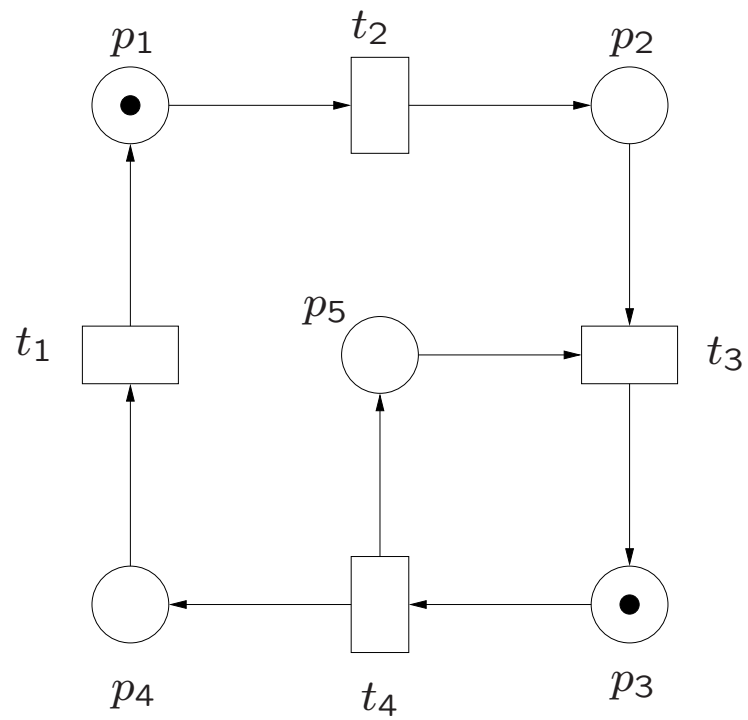

Fig. 39. A **marked graph**: live and not safe.

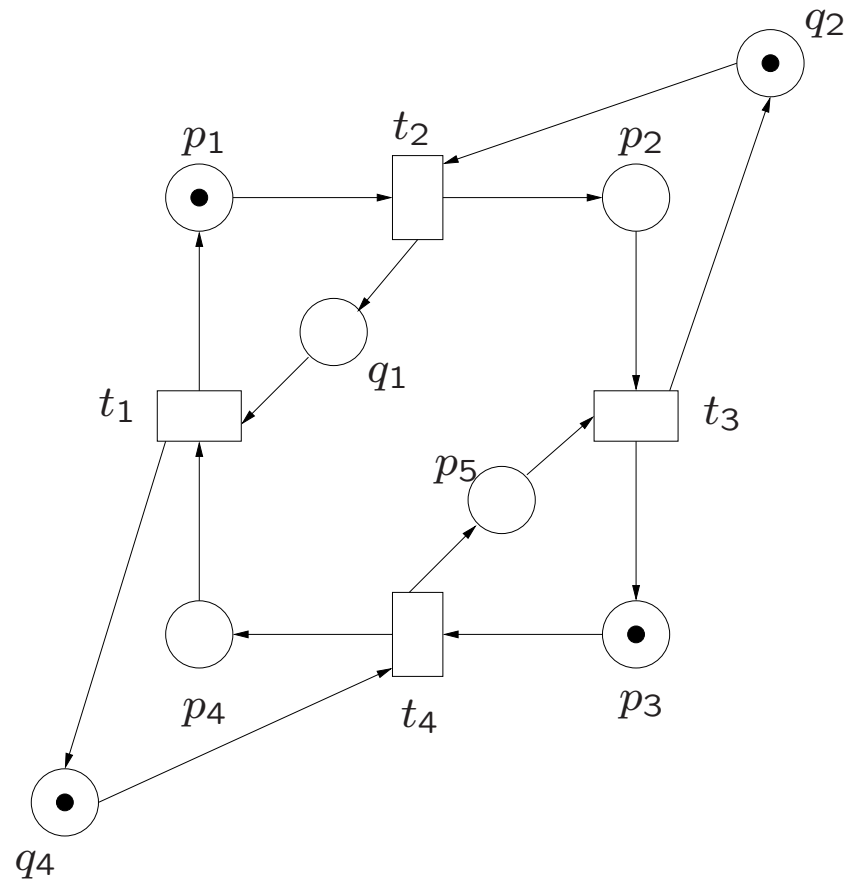

Fig. 48. The result of complementing p_1 , p_2 , p_4 in Fig. 39: live and safe.

Theorem 59. If a reduced EN system M is covered by sequential components, then M is contact-free.
(but not the other way round!)

Corollary 207. Let M be a reduced EN system which, moreover, is a marked graph. Then M is contact-free iff M is covered by sequential components.

Theorem 208. Let M be a marked graph.
Then M can be started with a live and safe configuration
iff each place of M belongs to a cycle.

The proof from right to left does not have to be known for the exam

9.7. Free-Choice Systems

Definition 209. A *free-choice system* is a P/T system $M = (P, T, F, W, C_{in})$ such that

(1) for all $(x, y) \in F$, $W(x, y) = 1$, and

(2) for all $(p, t) \in F \cap (P \times T)$, $p^\bullet = \{t\}$ or $\bullet t = \{p\}$.

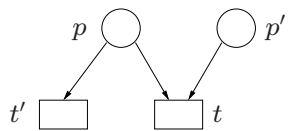

Fig. 97. Forbidden in free-choice systems.

A marked graph is always a free-choice system.

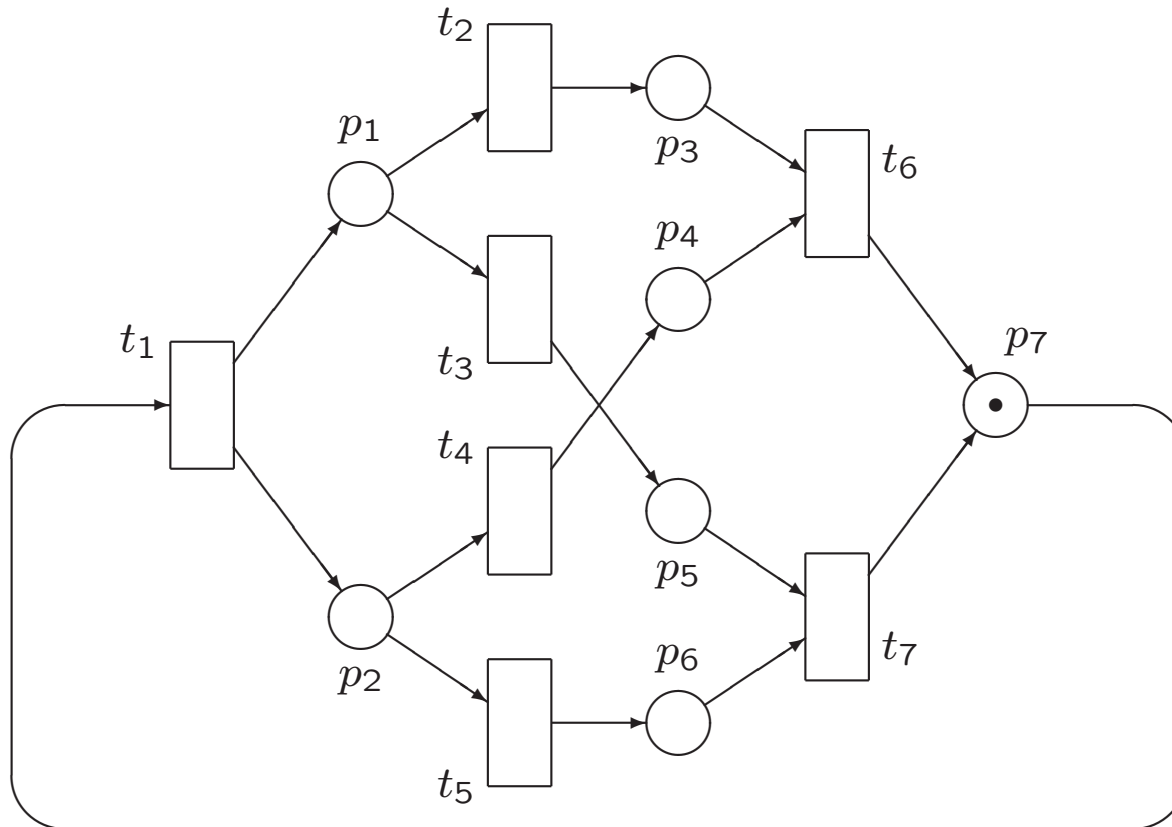

Fig. 98. A free-choice system.

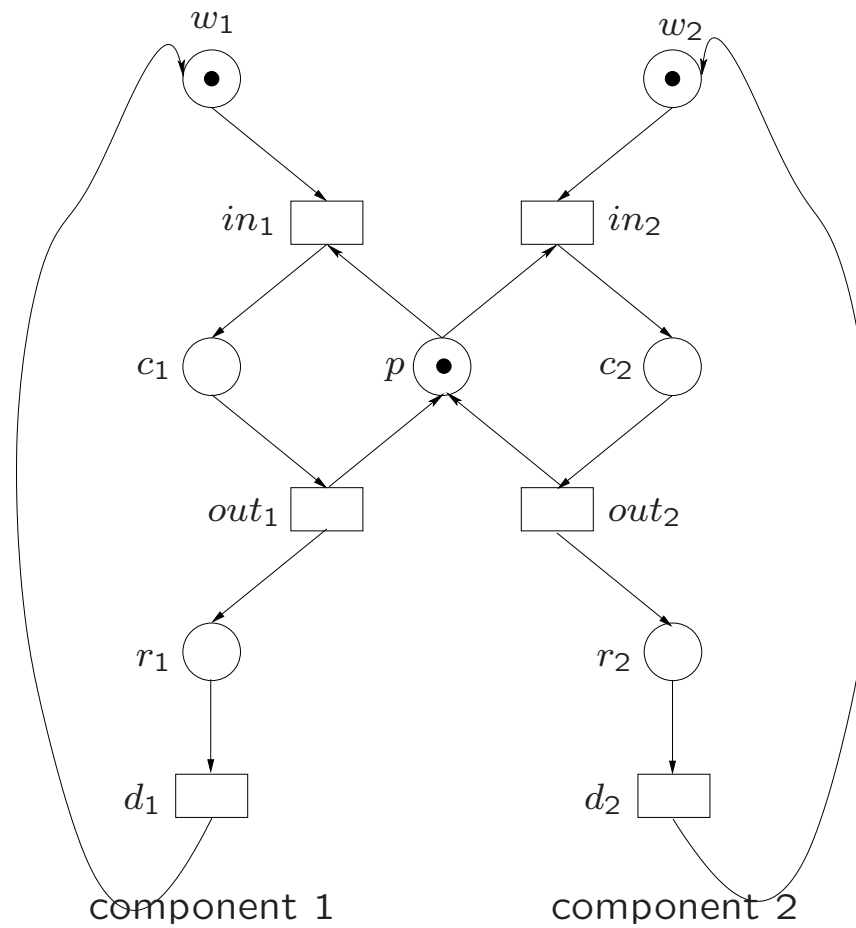

Fig. 5. The mutual exclusion problem: not free-choice (and not confusion-free).

Definition 210. Let M be a P/T system and let $S \subseteq P_M$.

(1) S is a *siphon* if $\bullet S \subseteq S^\bullet$.

(2) S is a *trap* if $S^\bullet \subseteq \bullet S$.

Theorem 211. Let $M = (P, T, F, W, C_{in})$ be a P/T system and let $S \subseteq P$.

(1) If S is a siphon and $C_{in}(p) = 0$ for every $p \in S$, then $C(p) = 0$ for every $C \in \mathbb{C}_M$ and every $p \in S$.

(2) If S is a trap and there is a $p \in S$ with $C_{in}(p) > 0$, then for every $C \in \mathbb{C}_M$ there is a $p' \in S$ with $C(p') > 0$.

Theorem 212. Let M be a free-choice system without isolated places. Then

M is live iff
every nonempty siphon contains a trap
that has at least one token in $(C_{in})_M$.

Without a proof

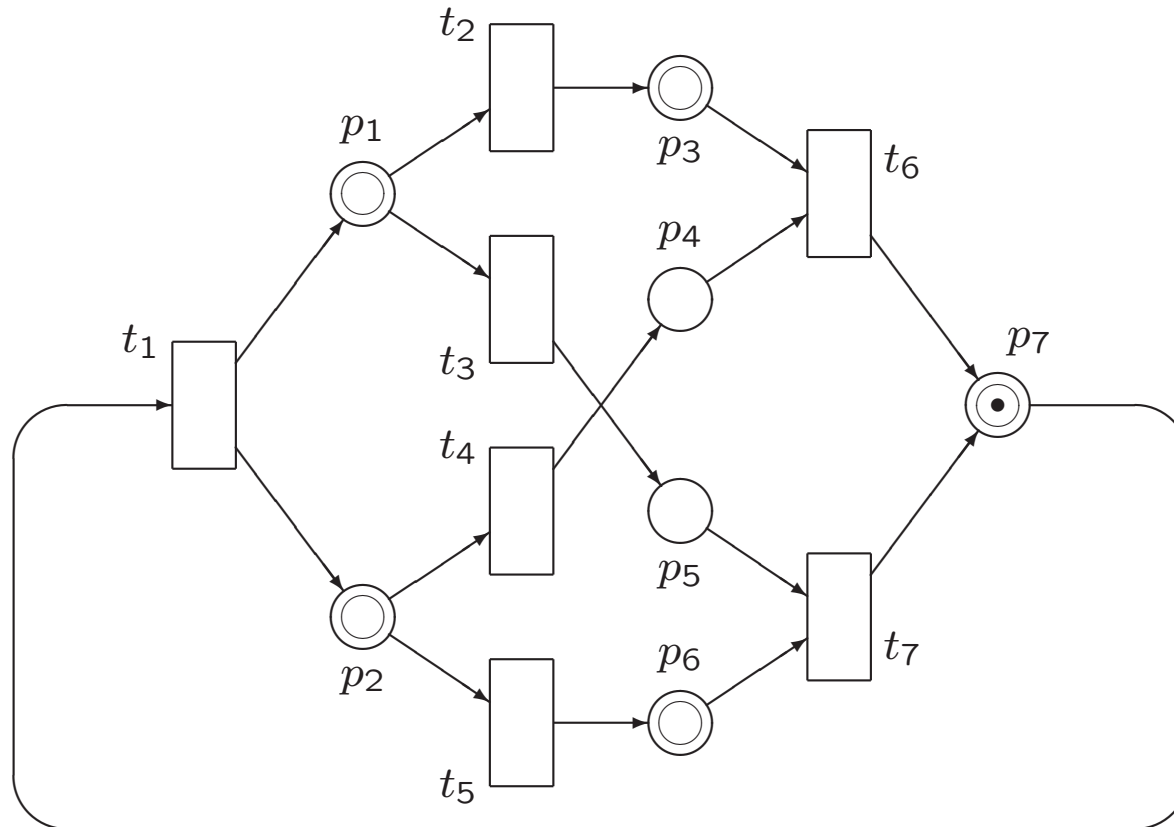

Fig. 98. A free-choice system with a syphon.

Theorem 213. Let M be a live free-choice system without isolated places. Then

M is safe iff

M is covered by sequential components.

Without a proof