

Parallel Graph Algorithms

Basic Definitions

- An *undirected graph* G is a pair (V, E) , where V is a finite set of points called *vertices* and E is a finite set of *edges*.
- An *edge* $e \in E$ is an **unordered** pair (u, v) , where u and $v \in V$.
- In a directed graph, the edge e is an **ordered** pair (u, v) . An edge (u, v) is *incident from / outgoing edge of* vertex u and is *incident to / incoming edge of* vertex v .
- A *path* from a vertex v to a vertex u is a sequence $\langle v_0, v_1, v_2, \dots, v_k \rangle$ of vertices, where $v_0 = v$, $v_k = u$, and $(v_i, v_{i+1}) \in E$ for $i = 0, 1, \dots, k-1$.
- The *length of a path* is defined as the number of edges in the path.

Representations (Undirected Graphs)

Adjacency **matrix** representation

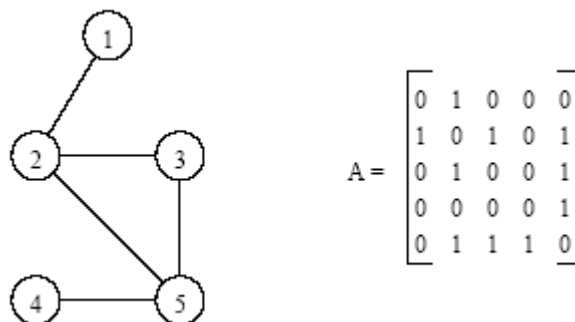

Adjacency **list** representation

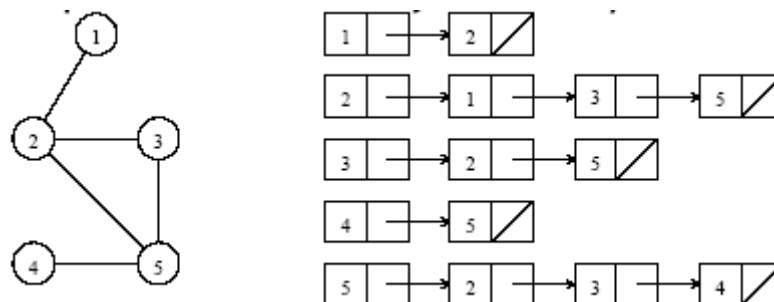

Problem 1: Minimum Spanning Tree

- A *spanning tree* of an undirected graph G is a sub-graph of G , which is a tree containing all the vertices of G .
- In a weighted graph, the weight of a subgraph is the sum of the weights of the edges in the sub-graph.
- A *minimum spanning tree (MST)* for a weighted undirected graph is a spanning tree with minimum weight.

In a Picture

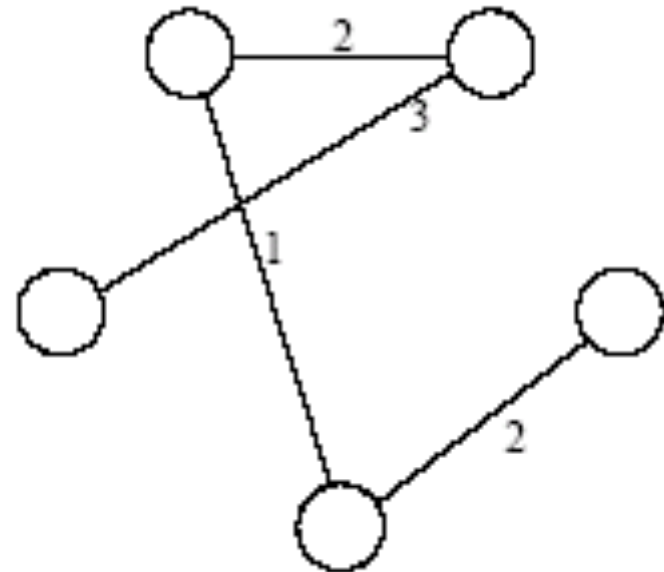
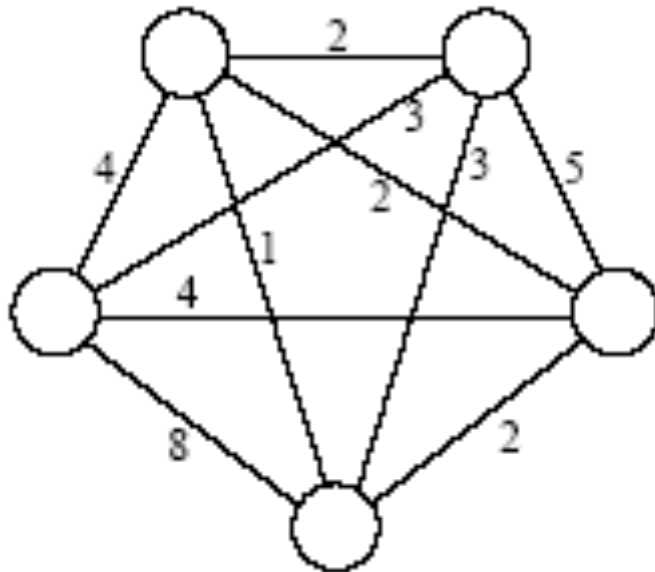

Relationship with Traveling Salesman Problem (TSP)

- Normally for TSP **complete** graphs are used (there is always a route to two cities no matter how long it takes)
- An incomplete graph for MST can be completed by adding edges with a very large weight (note that this will not have any effect on the solution)
- A **solution of the TSP** yields a cycle with minimal weight. By deleting any edge this would **result in a spanning tree**
- So a solution of TSP cannot have less weight than the weight of the MST
- So the weight of **MST is a lower bound** on the weight of TSP

Sequential Algorithms for MST

- Borůvka's algorithm (1926), Kruskal's algorithm (1956) and Prim's algorithm (1957)
- (Historical note) Borůvka's algorithm was used in 1926 to construct an efficient electricity network in Moravia (Czech Republic)
- Kruskal's and Prim's algorithm are both based on the selecting a single lightest weight edge in each step of the algorithm

Light-Edge Property

Given a weighted undirected graph $G = (V, E)$, then for any cut set $S \subseteq E$, the minimal weighted edge in S has to be an edge of the MST

A cut set S cuts the graph into two sets U and $V \setminus U$ such that any path from a node x in U to a node y in $V \setminus U$ contains an edge from S

Proof: Assume we have a cut set S which contains an edge $e=(x,y)$, which is not part of the MST. Then there is a path P in MST, which connects x and y and which does not contain e . So next to e there must be an edge e' in S with e' on the path P . Now add e to the $MST = MST'$, then e and e' are part of a cycle in MST' . Delete e' from MST' , and we obtain another MST with a lesser weight ($w(e) < w(e')$). Contradiction.

Kruskal's Algorithm

As described by Kruskal in 1956:

“Perform the following step as many times as possible: Among the edges of G not yet chosen, choose the shortest edge which does not form any loops with those edges already chosen”

Prim's Algorithm

PRIM_MST(V, E, w, r): Given V, E , and w weight function, build MST starting from vertex r

```
1.  procedure PRIM_MST( $V, E, w, r$ )
2.  begin
3.       $V_T := \{r\};$ 
4.       $d[r] := 0;$ 
5.      for all  $v \in (V - V_T)$  do
6.          if edge  $(r, v)$  exists set  $d[v] := w(r, v);$ 
7.          else set  $d[v] := \infty;$ 
8.      while  $V_T \neq V$  do
9.          begin
10.             find a vertex  $u$  such that  $d[u] := \min\{d[v] | v \in (V - V_T)\};$ 
11.              $V_T := V_T \cup \{u\};$ 
12.             for all  $v \in (V - V_T)$  do
13.                  $d[v] := \min\{d[v], w(u, v)\};$ 
14.             endwhile
15.          end PRIM_MST
```

(a) Original graph

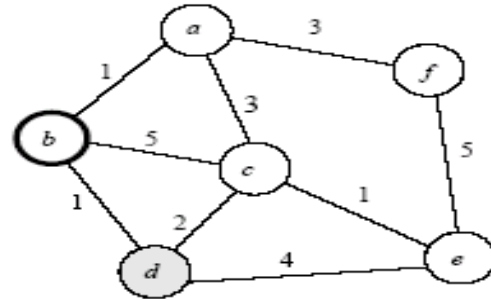

	a	b	c	d	e	f
d[]	1	0	5	1	∞	∞
a	0	1	3	∞	∞	3
b	1	0	5	1	∞	∞
c	3	5	0	2	1	∞
d	∞	1	2	0	4	∞
e	∞	∞	1	4	0	5
f	2	∞	∞	∞	5	0

(b) After the first edge has been selected

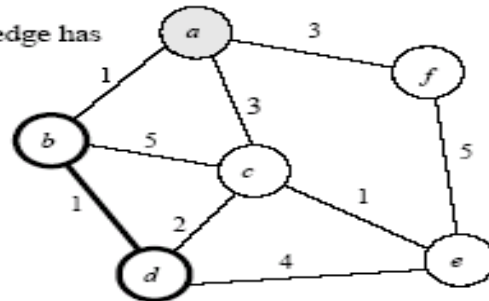

	a	b	c	d	e	f
d[]	1	0	2	1	4	∞
a	0	1	3	∞	∞	3
b	1	0	5	1	∞	∞
c	3	5	0	2	1	∞
d	∞	1	2	0	4	∞
e	∞	∞	1	4	0	5
f	2	∞	∞	∞	5	0

(c) After the second edge has been selected

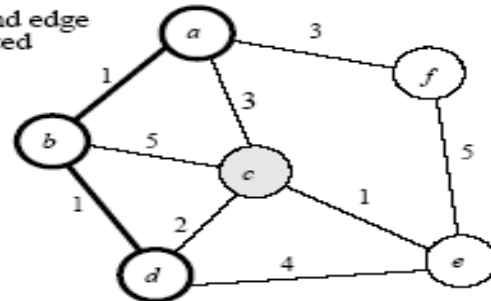

	a	b	c	d	e	f
d[]	1	0	2	1	4	3
a	0	1	3	∞	∞	3
b	1	0	5	1	∞	∞
c	3	5	0	2	1	∞
d	∞	1	2	0	4	∞
e	∞	∞	1	4	0	5
f	2	∞	∞	∞	5	0

(d) Final minimum spanning tree

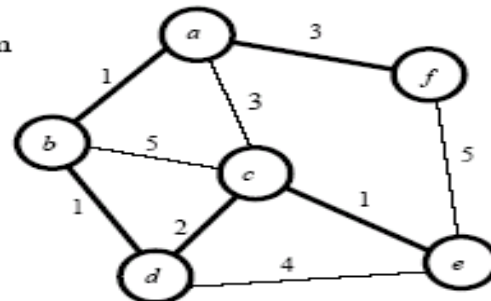

	a	b	c	d	e	f
d[]	1	0	2	1	1	3
a	0	1	3	∞	∞	3
b	1	0	5	1	∞	∞
c	3	5	0	2	1	∞
d	∞	1	2	0	4	∞
e	∞	∞	1	4	0	5
f	2	∞	∞	∞	5	0

Prim's Algorithm: Parallel Formulation

- The algorithm works in n outer iterations - it is hard to execute these iterations concurrently.
- The inner loop is relatively easy to parallelize. Let p be the number of processes, and let n be the number of vertices.
- The adjacency matrix is partitioned in a 1-D block fashion (**column slices**), with distance vector d partitioned accordingly. **See next slide.**
- In each step, each processor selects the **locally closest** node, followed by a **global reduction to select globally closest** node.
- This node is inserted into MST, and the choice is broadcasted to all processors.
- Each processor updates its part of the d vector locally.

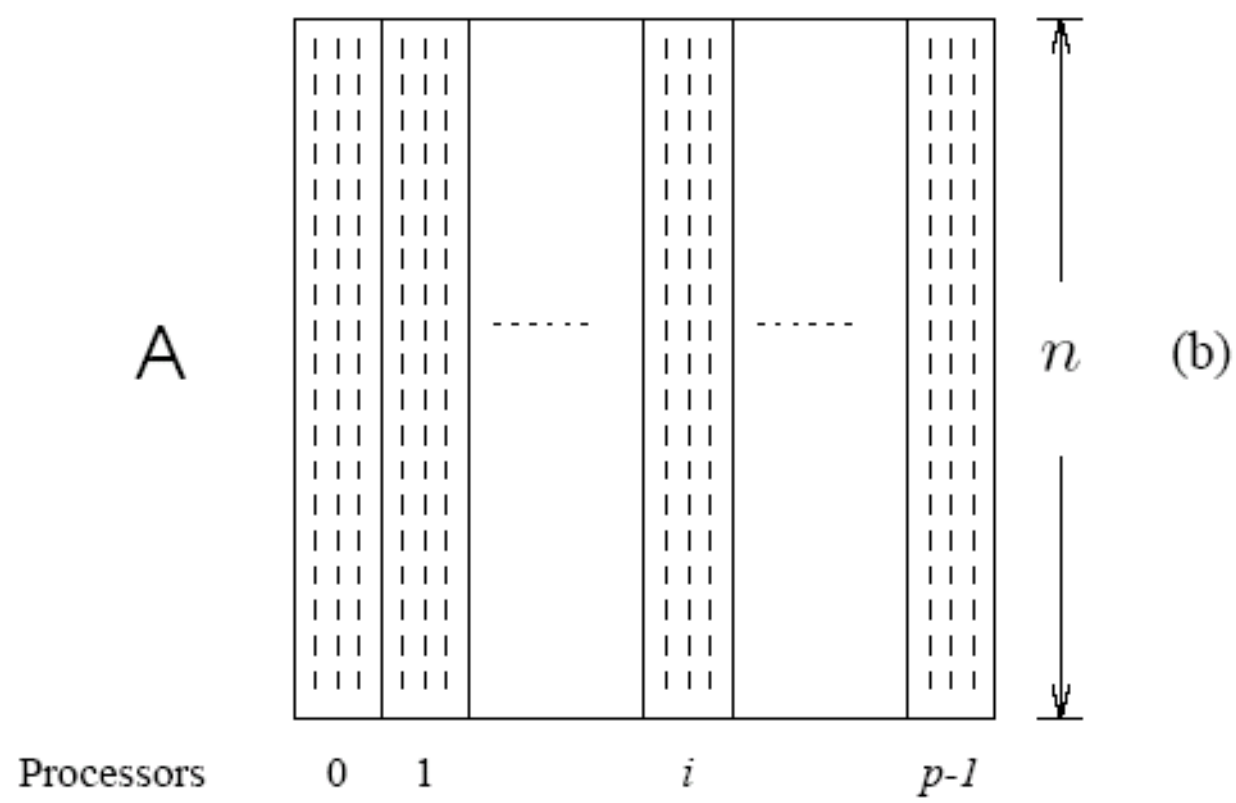
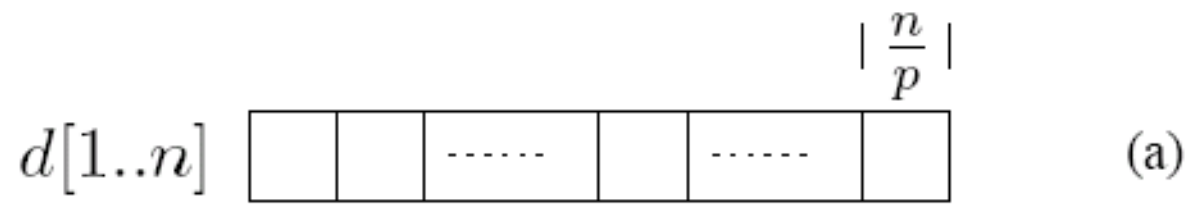

Computational Aspects

- The cost to select the minimum entry is $O(n/p + \log p)$.
- The cost of a broadcast is $O(\log p)$.
- The cost of local updation of the d vector is $O(n/p)$.
- The parallel time per iteration is $O(n/p + \log p)$.
- The total parallel time is given by $O(n^2/p + n \log p)$.

Borůvka's Algorithm (1926)

While there are edges remaining:

- (1) select the minimum weight edge out of each vertex and contract each connected component defined by these edges into a vertex;
- (2) remove self edges, and when there are redundant edges keep the minimum weight edge; and
- (3) add all selected edges to the MST.

Note that this formulation is inherently parallel while computers were not invented at that time, or maybe because computers were not invented yet

Example

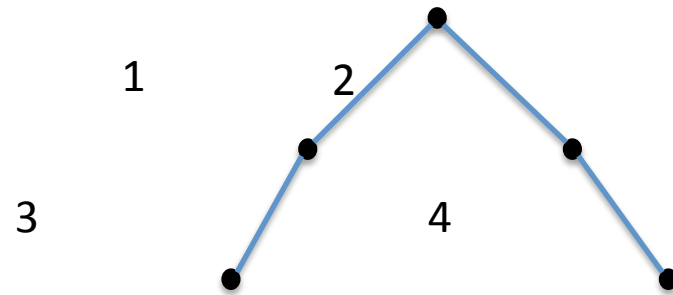
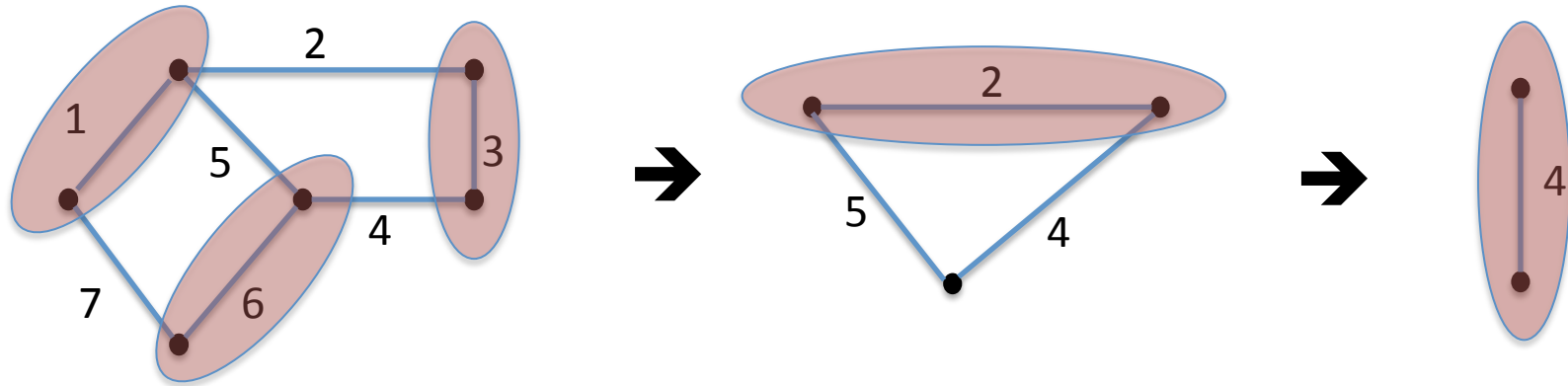

Notes to Borůvka's Algorithm

- At each step the contractions of nodes u and v with (u,v) a minimal edge can be executed in parallel with the contraction of nodes x and w with (x,w) a minimal edge, if $v \neq x$ and $u \neq w$. (Note, $u \neq x$ and $v \neq w$ automatically holds)
- So at each step at least $\frac{1}{2} |V|$ vertices are eliminated \rightarrow at most $\log(n)$ steps are required
- However, also the amount of available parallelism is reduced by an half after each step \rightarrow uneven load balance

Input Data Partitioning

- Recall **separator sets** (nested dissection) for undirected graphs, based on levellization (BFS).
- The set of nodes V is divided into P disjoint subsets and separator sets:

$$V = V_1 \cup S_2 \cup V_2 \cup S_3 \dots S_p \cup V_p$$

P = number of processors and $|V_i|$ about equal for all i

- Distribute the edges E such that each processor i has

$$E_i = \{ (u,v) \mid u \in V_i \text{ and } v \in V_i \}, \text{ and}$$

$$\text{Left_}E_i = \{ (u,v) \mid u \in S_i \text{ and } v \in V_i \}, \text{ and}$$

$$\text{Right_}E_i = \{ (u,v) \mid u \in V_i \text{ and } v \in S_{i+1} \}$$

- ➔ First phase every processor computes in parallel an MST for each E_i
- ➔ Second these partial MST's are knitted together by synchronizing the choice of minimum weight edge of $\text{Left_}E_i$ with $\text{Right_}E_{i+1}$

Problem 2: Single-Source Shortest Paths

- For a weighted graph $G = (V, E, w)$, the *single-source shortest paths* problem is to find the shortest paths from a vertex $v \in V$ to all other vertices in V .
- Dijkstra's algorithm is similar to Prim's algorithm. It maintains a set of nodes for which the shortest paths are known.
- It grows this set based on the **node closest to source using one of the nodes in the current shortest path set**.

Dijkstra's Algorithm

```
1.  procedure DIJKSTRA_SINGLE_SOURCE_SP( $V, E, w, s$ )
2.  begin
3.       $V_T := \{s\};$ 
4.      for all  $v \in (V - V_T)$  do
5.          if  $(s, v)$  exists set  $l[v] := w(s, v);$ 
6.          else set  $l[v] := \infty;$ 
7.      while  $V_T \neq V$  do
8.          begin
9.              find a vertex  $u$  such that  $l[u] := \min\{l[v] | v \in (V - V_T)\};$ 
10.              $V_T := V_T \cup \{u\};$ 
11.             for all  $v \in (V - V_T)$  do
12.                  $l[v] := \min\{l[v], l[u] + w(u, v)\};$ 
13.             endwhile
14.     end DIJKSTRA_SINGLE_SOURCE_SP
```

Dijkstra's Algorithm: Parallel Formulation

- Very similar to the parallel formulation of Prim's algorithm for minimum spanning trees.
- The weighted adjacency matrix is partitioned using the 1-D block mapping (**column slicing**).
- Each process selects, locally, the node closest to the source, followed by a global reduction to select next node.
- The node is broadcast to all processors and the l -vector updated.

Problem 3: All-Pairs Shortest Paths

- Given a weighted graph $G(V, E, w)$, the *all-pairs shortest paths* problem is to find the shortest paths between all pairs of vertices $v_i, v_j \in V$.
- A number of algorithms are known for solving this problem: Matrix-Multiplication Based algorithm, Dijkstra's algorithm, Floyd's algorithm.

Matrix-Multiplication Based Algorithm

- Consider the multiplication of the weighted adjacency matrix with itself - except, in this case, we replace the **multiplication operation** in matrix multiplication **by addition**, and the **addition operation** by **minimization**.
- Notice that the product of weighted adjacency matrix with itself returns a matrix that contains shortest paths of length 2 between any pair of nodes.
- It follows from this argument that A^n contains all shortest paths.

Computational Aspects

- For (semi) complete graphs and sequential execution:
 - A^n is computed by doubling powers - i.e., as A, A^2, A^4, A^8 , and so on.
 - We need $\log n$ (dense) matrix multiplications, each taking time $O(n^3)$.
 - The serial complexity of this procedure is $O(n^3 \log n)$.
- For (semi) complete graphs and parallel execution:
 - Each of the $\log n$ matrix multiplications can be performed in parallel.
 - We can use $n^3 / \log n$ processors to compute each matrix-matrix product in time $\log n$.
 - The entire process takes $O(\log^2 n)$ time.

Note that for incomplete graphs (leading to sparse matrices) this complexity does not change very much, because sparse x sparse matrix multiply very easily lead to full matrices.

Dijkstra's Algorithm for All-Pairs Shortest Paths

Sequential Execution:

- Execute n instances of the single-source shortest path problem, one for each of the n source vertices.
- Complexity is $O(n^3)$.

Parallel Execution:

- execute each of the n shortest path problems on a different processor (source partitioned), or
- use a parallel formulation of the shortest path problem to increase concurrency (source parallel)

Source Partitioned Formulation

- Use n processors, each processor P_i finds the shortest paths from vertex v_i to all other vertices by executing Dijkstra's sequential single-source shortest paths algorithm.
- It requires no interprocess communication (provided that the adjacency matrix is replicated at all processes).
- The parallel run time of this formulation is: $\Theta(n^2)$.
- While the algorithm is cost optimal, it can only use n processors.

Source Parallel Formulation

- In this case, each of the shortest path problems is further executed in parallel. We can therefore use up to n^2 processors.
- Given p processors ($p > n$), each single source shortest path problem is executed by p/n processors.
- Using previous results, this takes time:

$$T_P = \overbrace{\Theta\left(\frac{n^3}{p}\right)}^{\text{computation}} + \overbrace{\Theta(n \log p)}^{\text{communication}}.$$

- For cost optimality, we have $p = O(n^2/\log n)$ and the isoefficiency is $\Theta((p \log p)^{1.5})$.

Floyd's Algorithm

- For any pair of vertices $v_i, v_j \in V$, consider all paths from v_i to v_j whose intermediate vertices belong to the set $\{v_1, v_2, \dots, v_k\}$. Let $p_{i,j}^{(k)}$ (of weight $d_{i,j}^{(k)}$) be the minimum-weight path among them.
- If vertex v_k is not in the shortest path from v_i to v_j , then $p_{i,j}^{(k)}$ is the same as $p_{i,j}^{(k-1)}$.
- If v_k is in $p_{i,j}^{(k)}$, then we can break $p_{i,j}^{(k)}$ into two paths
 - one from v_i to v_k and
 - one from v_k to v_j

Each of these paths uses vertices from $\{v_1, v_2, \dots, v_{k-1}\}$.

As a consequence:

From these observations, the following recurrence relation follows:

$$d_{i,j}^{(k)} = \begin{cases} w(v_i, v_j) & \text{if } k = 0 \\ \min \left\{ d_{i,j}^{(k-1)}, d_{i,k}^{(k-1)} + d_{k,j}^{(k-1)} \right\} & \text{if } k \geq 1 \end{cases}$$

This equation must be computed for each pair of nodes and for $k = 1, n$. The serial complexity is $O(n^3)$.

In (pseudo) code

```
1.  procedure FLOYD_ALL_PAIRS_SP(A)
2.  begin
3.       $D^{(0)} = A;$ 
4.      for  $k := 1$  to  $n$  do
5.          for  $i := 1$  to  $n$  do
6.              for  $j := 1$  to  $n$  do
7.                   $d_{i,j}^{(k)} := \min \left( d_{i,j}^{(k-1)}, d_{i,k}^{(k-1)} + d_{k,j}^{(k-1)} \right);$ 
8.  end FLOYD_ALL_PAIRS_SP
```

Floyd's Algorithm: Parallel Execution

- Matrix $D^{(k)}$ is divided into p blocks of size $(n / \sqrt{p}) \times (n / \sqrt{p})$.
- Each processor updates its part of the matrix during each iteration.
- To compute $d_{l,k}^{(k-1)}$ processor $P_{i,j}$ must get $d_{l,k}^{(k-1)}$ and $d_{k,r}^{(k-1)}$.
- In general, during the k^{th} iteration, each of the \sqrt{p} processes containing part of the k^{th} row send it to the $\sqrt{p} - 1$ processes in the same column.
- Similarly, each of the \sqrt{p} processes containing part of the k^{th} column sends it to the $\sqrt{p} - 1$ processes in the same row.

In a Picture

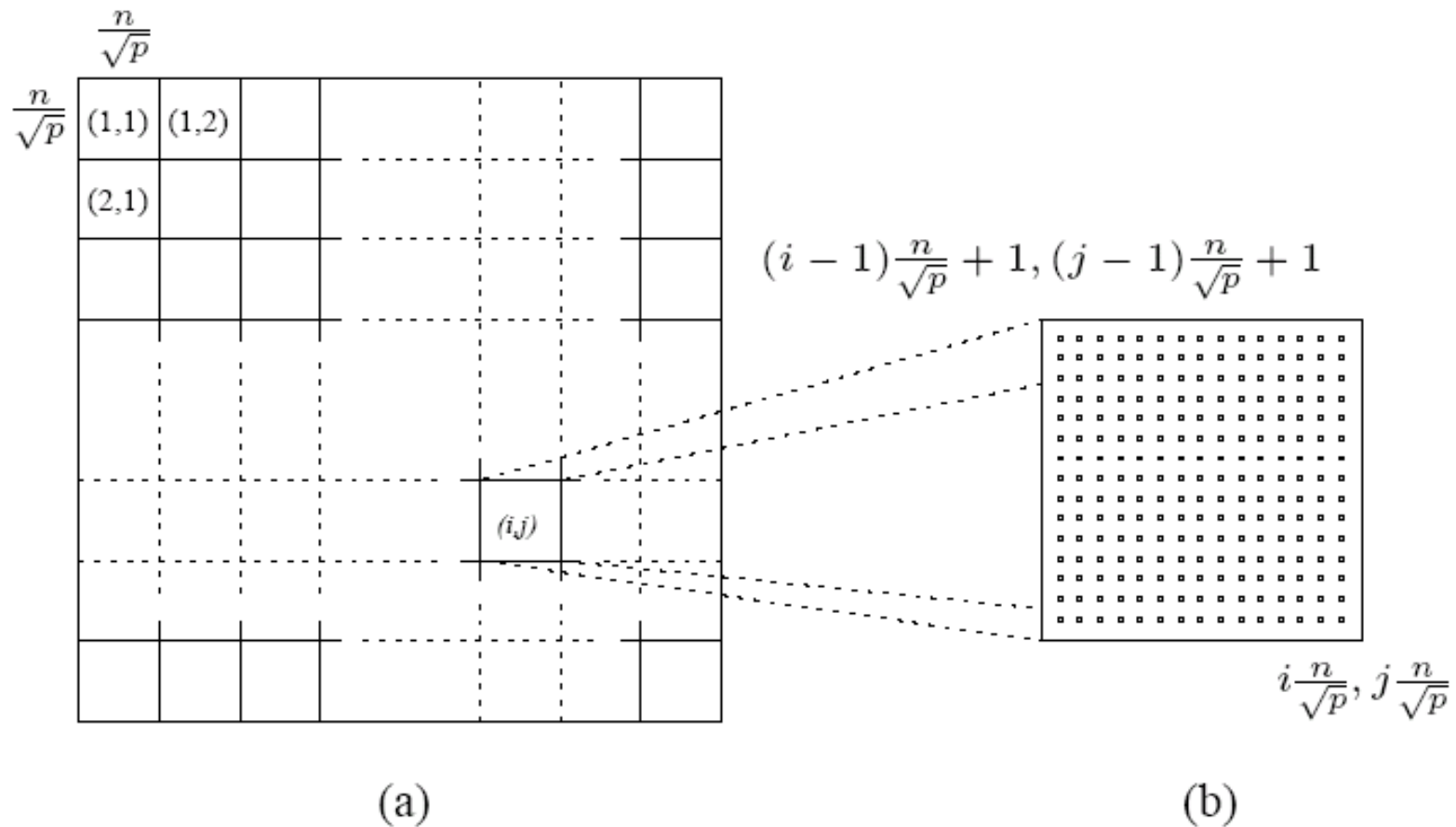

In a Picture: continued

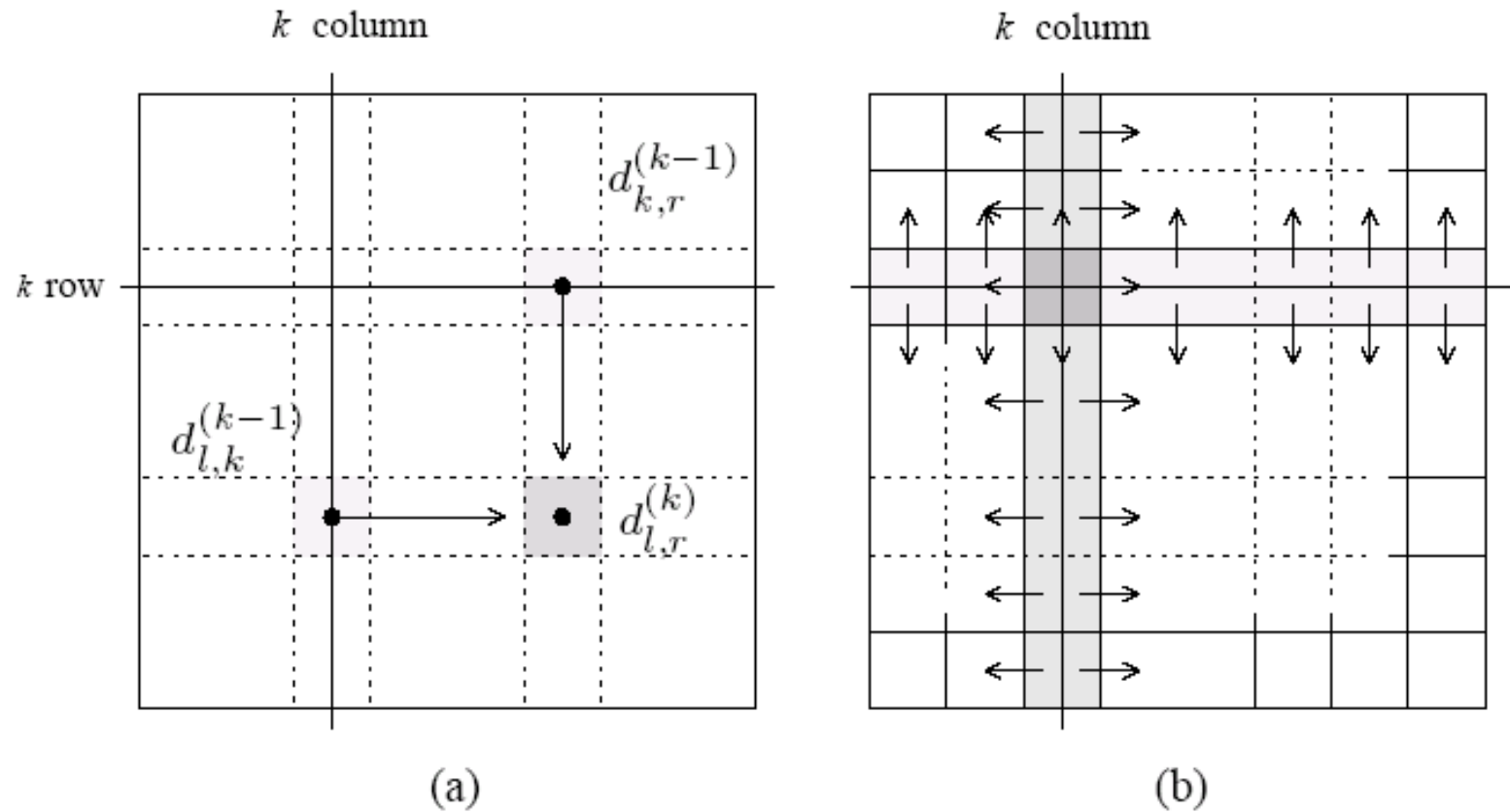

In (pseudo) code

```
1.  procedure FLOYD_2DBLOCK( $D^{(0)}$ )
2.  begin
3.      for  $k := 1$  to  $n$  do
4.          begin
5.              each process  $P_{i,j}$  that has a segment of the  $k^{th}$  row of  $D^{(k-1)}$ ;
6.                  broadcasts it to the  $P_{*,j}$  processes;
7.              each process  $P_{i,j}$  that has a segment of the  $k^{th}$  column of  $D^{(k-1)}$ ;
8.                  broadcasts it to the  $P_{i,*}$  processes;
9.              each process waits to receive the needed segments;
10.             each process  $P_{i,j}$  computes its part of the  $D^{(k)}$  matrix;
11.         end
12.     end FLOYD_2DBLOCK
```

Computational Aspects

- During each iteration of the algorithm, the k^{th} row and k^{th} column of processors perform a one-to-all broadcast along their rows/columns.
- The size of this broadcast is n/\sqrt{p} elements, taking time $\Theta((n \log p)/\sqrt{p})$.
- The synchronization step takes time $\Theta(\log p)$.
- The computation time is $\Theta(n^2/p)$.
- The parallel run time of the 2-D block mapping formulation of Floyd's algorithm is

$$T_P = \overbrace{\Theta\left(\frac{n^3}{p}\right)}^{\text{computation}} + \overbrace{\Theta\left(\frac{n^2}{\sqrt{p}} \log p\right)}^{\text{communication}}.$$