

**THEORY OF CONCURRENCY
EXAM**

Friday January 7, 2011, 10.00 - 13.00

This exam consists of 5 questions.

Answers may be given both in English and in het Nederlands.

Question 1

25 pt

Consider the EN system $M = (P, T, F, C_{in})$ drawn below, with initial configuration $C_{in} = \{p_2, p_3, p_6\}$.

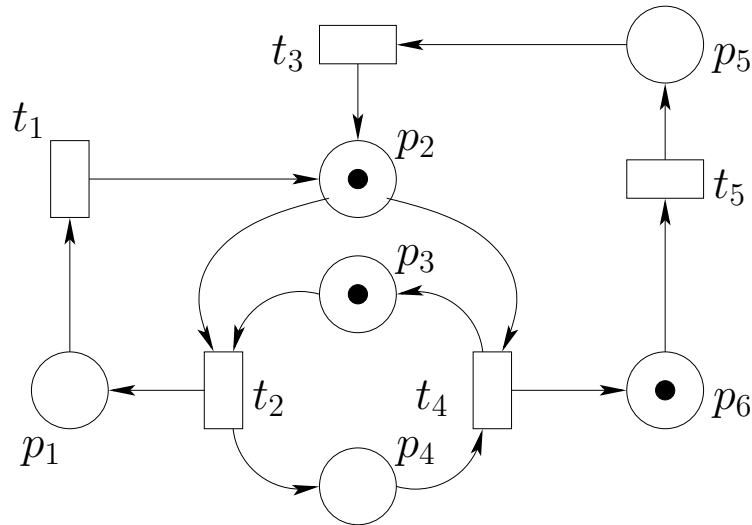

- (a) Give a firing sequence of M in which all transitions from T occur exactly once.

Demonstrate — using firing sequences — that $\{p_2, p_4, p_5\}$, $\{p_1, p_2, p_4\}$, and $\{p_1, p_2, p_3\}$ are reachable configurations of M .

- (b) Give the sequential configuration graph $SCG(M)$ of M .
(c) Give a definition for contact (in an EN system). Show that M is not contact-free.

Which transitions of M are useful? And which are live? Why?

- (d) Extend $SCG(M)$ to the configuration graph $CG(M)$ of M .
(e) Give all non-empty conflict sets $\mathbf{cfl}(t, C)$ with $C \in \mathbb{C}_M$ and $t \in T$.
(f) Define confusion and give all confusions of M together with an explanation of their type (conflict-increasing, conflict-decreasing or neither; symmetric or not).

Question 2

15 pt

- (a) When does a subset of places S of an EN system determine a subsystem?

Let $M = (P, T, F, C_{in})$ be the EN system from Question 1.

- (b) Find all $S \subseteq P$ that determine a subsystem of M and explain for each whether or not this subsystem is a sequential component.
(c) Does there exist a configuration $C \subseteq P$ such that $M' = (P, T, F, C)$ is covered by sequential components? Explain your answer carefully.

Question 3

20 pt

We are given the following labelled process net N :

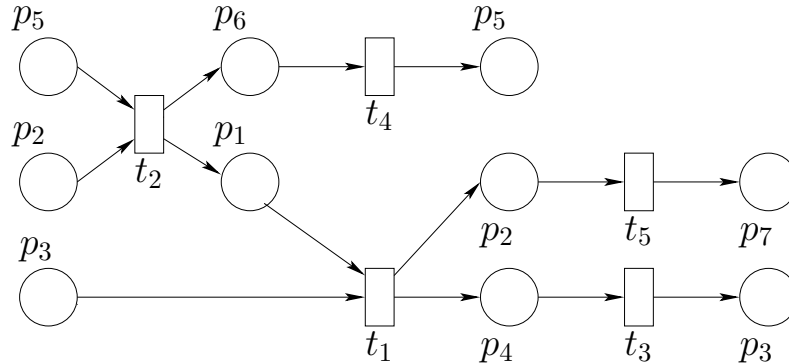

- Indicate (draw) 5 slices of N in its diagram.
- Give $\mathbf{ctr}(N)$, the contracted version of N , and its transitive closure $\mathbf{tra}(\mathbf{ctr}(N))$.
- Give a contact-free EN system M with 7 places and 5 transitions such that N is a process of M .
Give a firing sequence of M defining N .
- Determine $\mathbf{ind}(M)$, the independency relation of EN system M from (c).
- Give $\mathbf{words}(\mathbf{pru}(\mathbf{ctr}(N)))$ and explain using $\mathbf{ind}(M)$ that they all belong to the same trace.

Question 4

25 pt

Let $\underline{M} = \begin{pmatrix} 5 & -1 & -4 & 0 & 0 \\ 2 & 0 & -3 & 1 & 0 \\ -4 & 0 & 5 & 0 & 1 \\ 0 & 1 & 0 & -2 & -2 \end{pmatrix}$ be the matrix defined by the

P/T system M with initial configuration $C_{in} = (0, 0, 6, 0, 1)$.

- Draw M .
- Decide whether or not \mathbb{C}_M is finite using the finiteness algorithm.

Let M' be the P/T system obtained from M by changing the weight of (t_1, p_1) from 5 to 4. Otherwise M and M' are the same.

- Determine the p-invariants of M' .
- Use p-invariants to prove that M' is bounded.
- Compute integers $p, q, n \in \mathbb{Z}$ such that $C(p_1) + C(p_3) + pC(p_4) + qC(p_5) = n$ for all $C \in \mathbb{C}_{M'}$.

Question 5

15 pt

Let M be the following P/T system

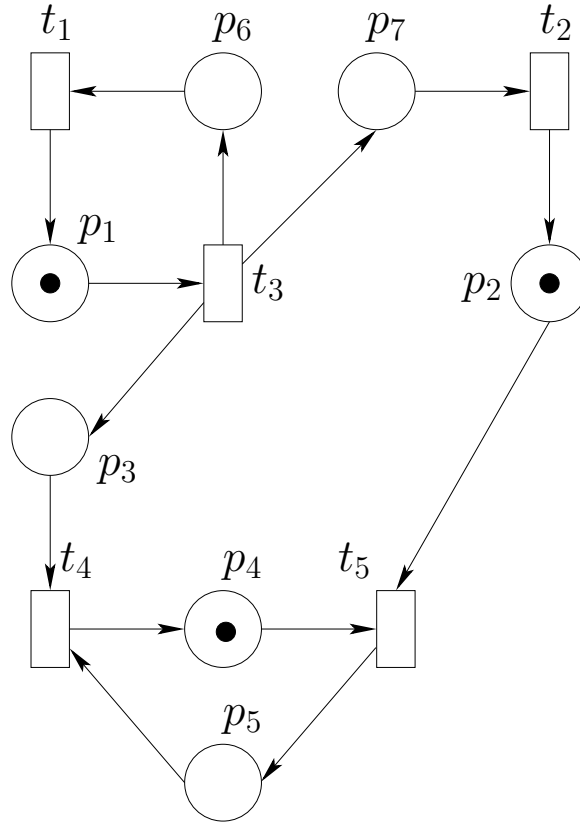

- Give the definition of marked graph and verify that M is a marked graph.
- Give all cycles of M together with their value.
- Is M live? Is M safe? Explain your answers.

Let N be the multi-net underlying M (M without tokens) with one new place p_8 added and two edges (t_5, p_8) and (p_8, t_3) each with weight 1.

- Give an initial configuration for N such that the resulting marked graph is live and safe. Explain your answer.

the end