

Theorie van Concurrency

voorjaar 2010

<http://www.liacs.nl/home/kleijn/thvc-0910.html>

vijfde college: 10 mrt 2010

5. Equivalences and Normal Forms afmaken

6. Processes beginnen

tweede werkgroep: 17 maart 2010

de opgaven bij 5. Equivalences and Normal Forms

en evt. begin 6. Processes

Theorem 54. For every EN system M there exists a reduced EN system M' that is configuration equivalent with M and that is covered by at most $\#P_M$ sequential components.

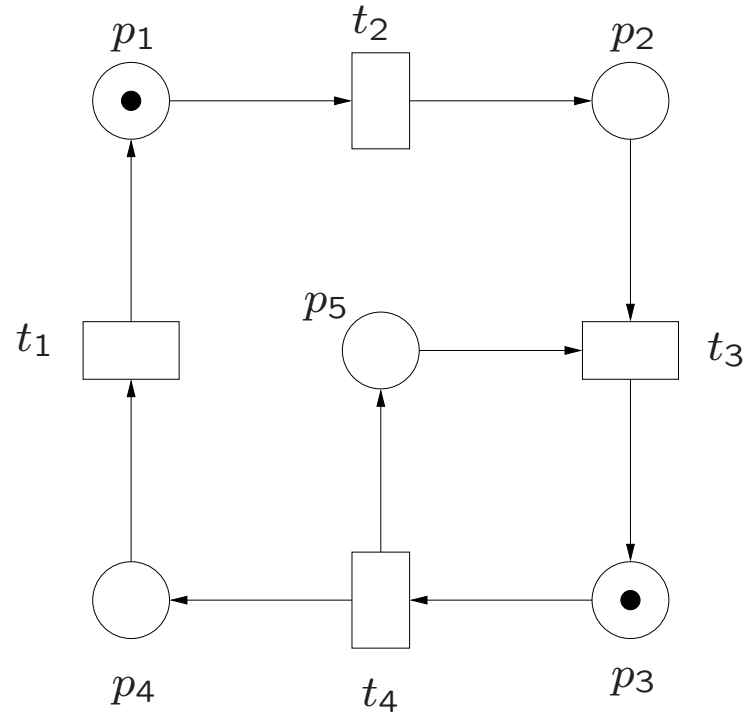

Fig. 39. An EN system with two nontrivial subsystems: $\{p_3, p_5\}$ (a sequential component) and $\{p_1, p_2, p_3, p_4\}$.

Definition 55. Let M be an EN system and let $p, q \in P_M$.

Then p and q are *complementary*, denoted by $p \text{ com } q$, if

$$p^\bullet = \bullet q \text{ and } \bullet p = q^\bullet.$$

Lemma 56. Let $M = (P, T, F, C_{in})$ be a reduced EN system.

For all $p, q \in P$,

$\{p, q\}$ is a sequential component of M

iff

$\#(C_{in} \cap \{p, q\}) = 1$ and p com q .

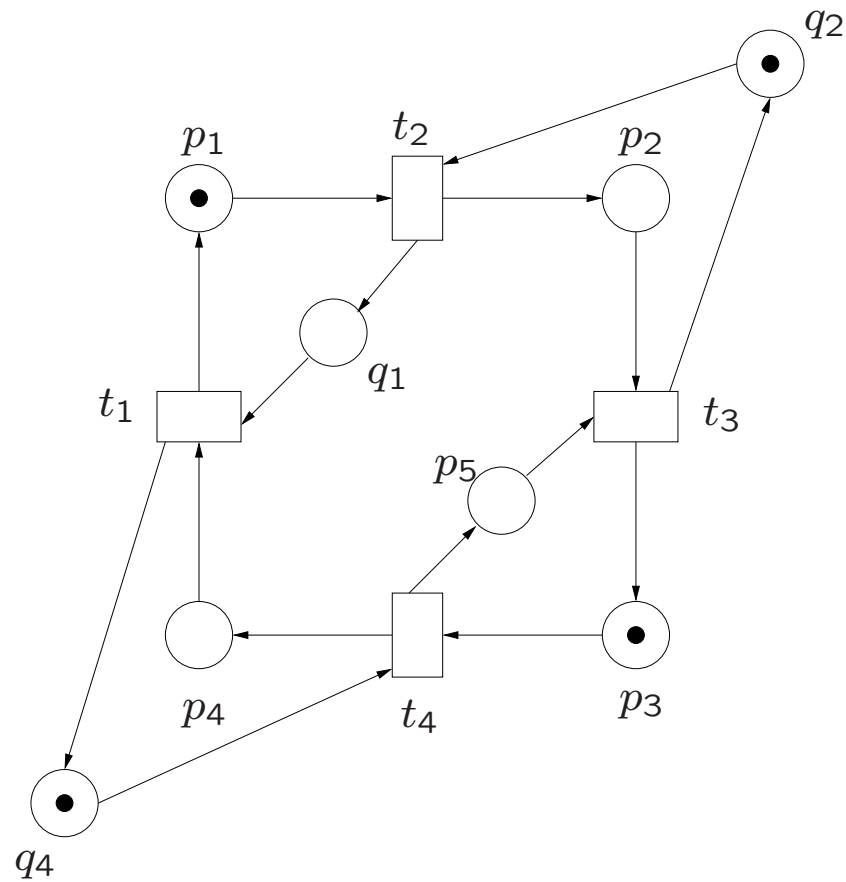

Fig. 48. The result of complementing p_1 , p_2 , p_4 in Fig. 39.

Theorem 57. Let M be a reduced EN system and let $p_0 \in P_M$.

Then there exists a reduced EN system M' that is configuration equivalent with M , such that:

- (1) $P_{M'} = P_M \cup \{q_0\}$ with $q_0 \notin P_M$,
- (2) $\{p_0, q_0\}$ is a sequential component of M' , and
- (3) for every $S \subseteq P_M$,
 S is a sequential component of M iff
 S is a sequential component of M' .

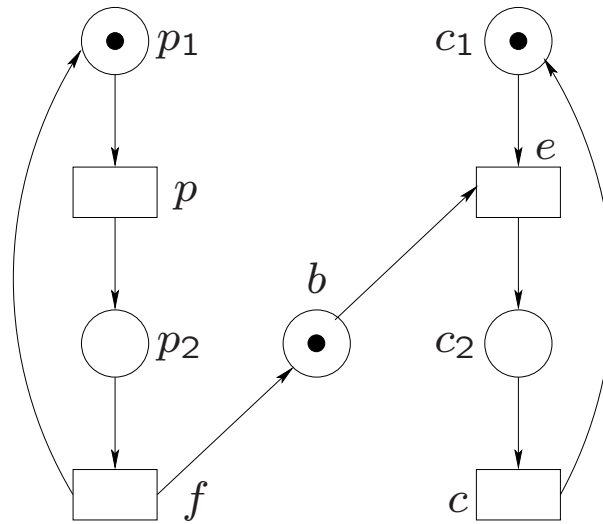

Fig. 12. Subsystems: $\{p_1, p_2\}$, the producer; $\{c_1, c_2\}$, the consumer; and $\{p_1, p_2, c_1, c_2\}$; otherwise trivial. The buffer is NOT a subsystem

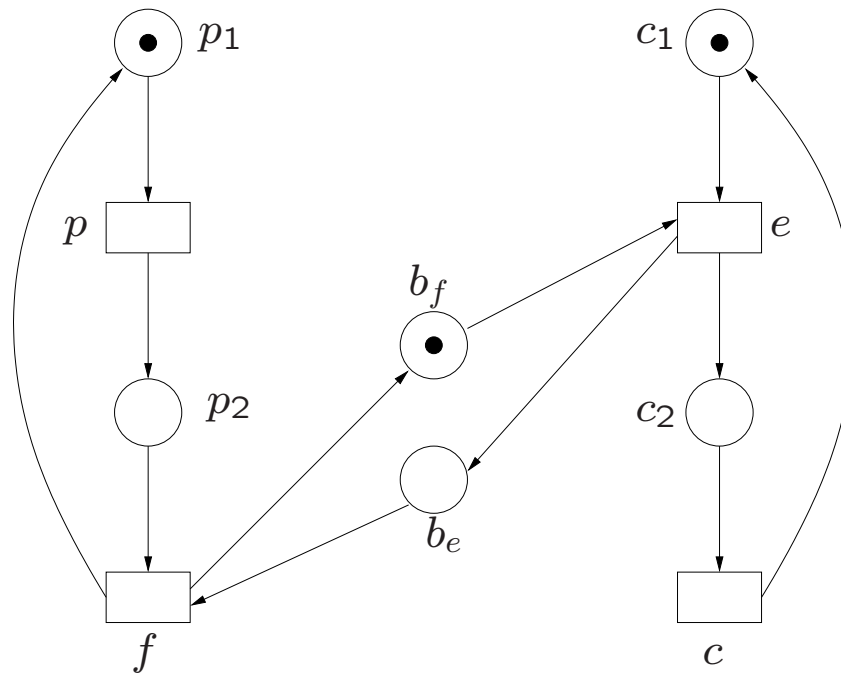

Fig. 49. The producer/consumer system with three sequential components.

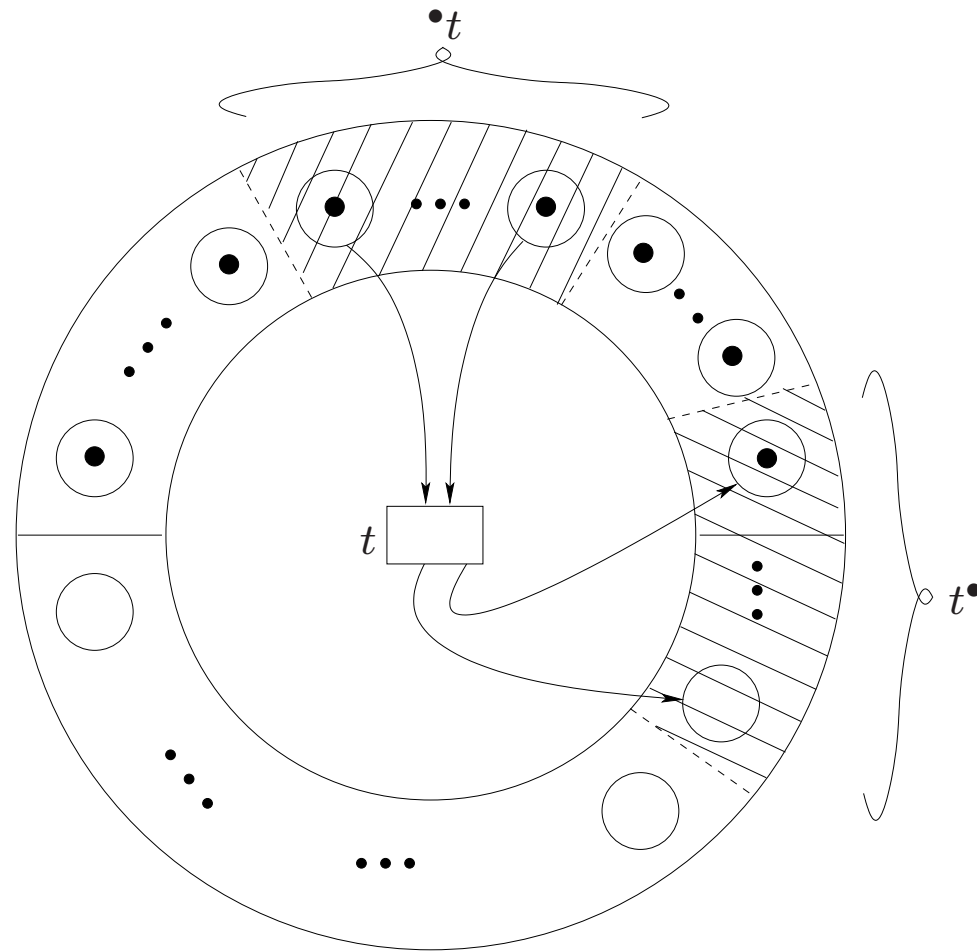

Fig. 50. Contact.

Definition 58. Let $M = (P, T, F, C_{in})$ be an EN system.

M is *contact-free* if for all $t \in T$ and $C \in \mathbb{C}_M$,

if $\bullet t \subseteq C$ then $t^\bullet \cap C = \emptyset$.

Theorem 59. If a reduced EN system M is covered by sequential components, then M is contact-free.

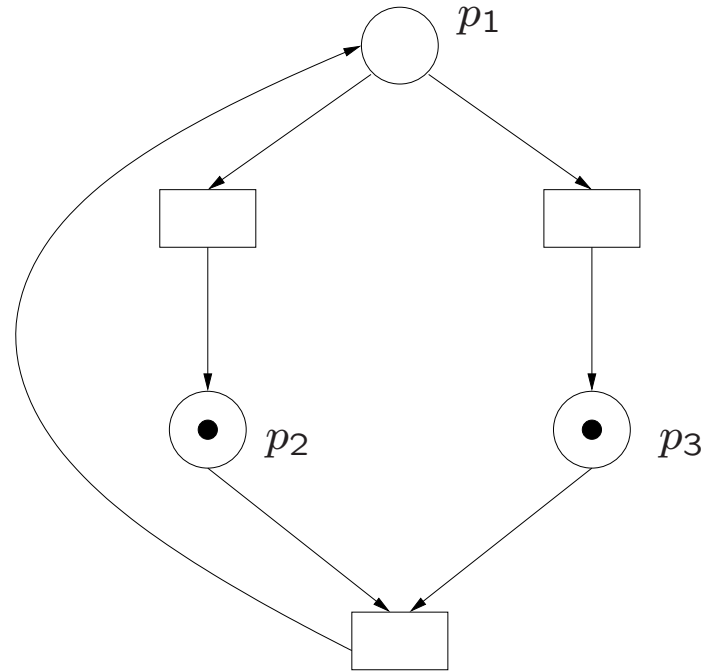

Fig. 51. A contact-free EN system without sequential components.

Theorem 60. For every EN system there exists a configuration equivalent reduced contact-free EN system.

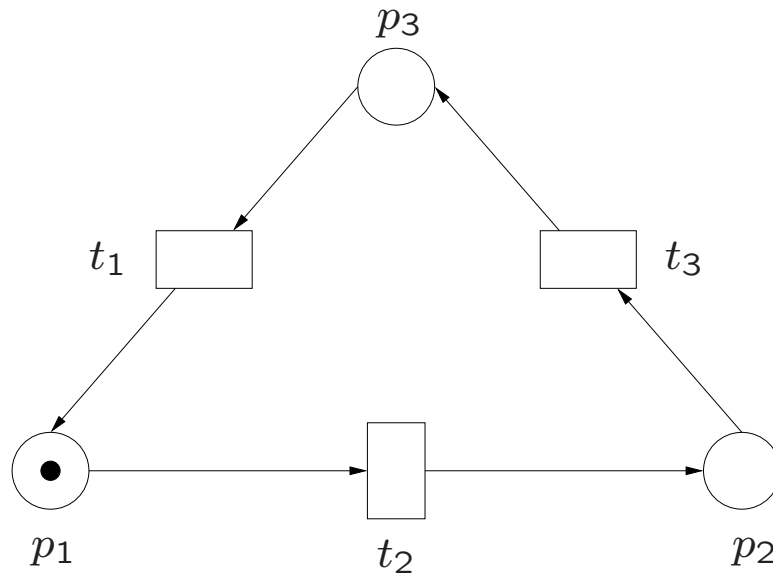

Fig. 47. A sequential EN system.

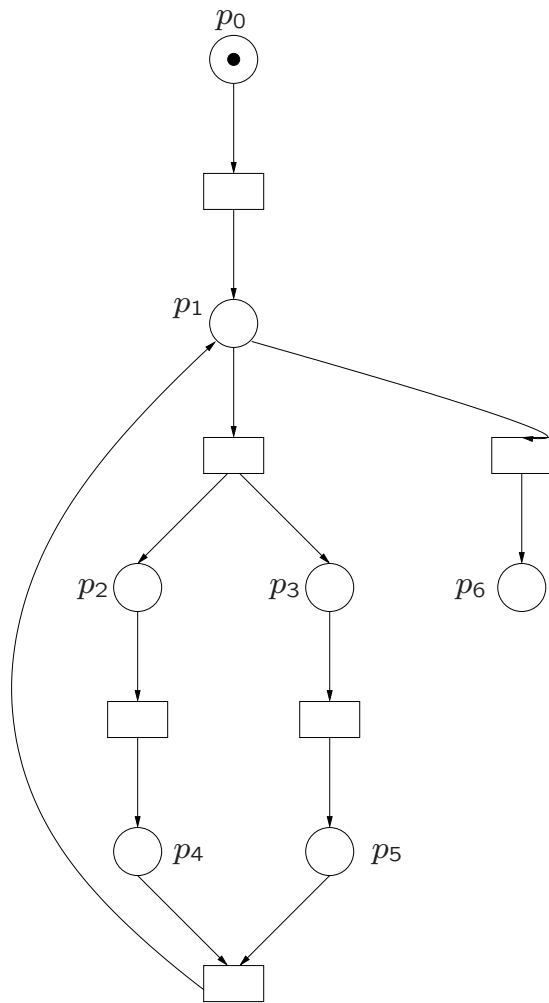

Fig. 15. Covered by (two) sequential components. Hence contact-free.

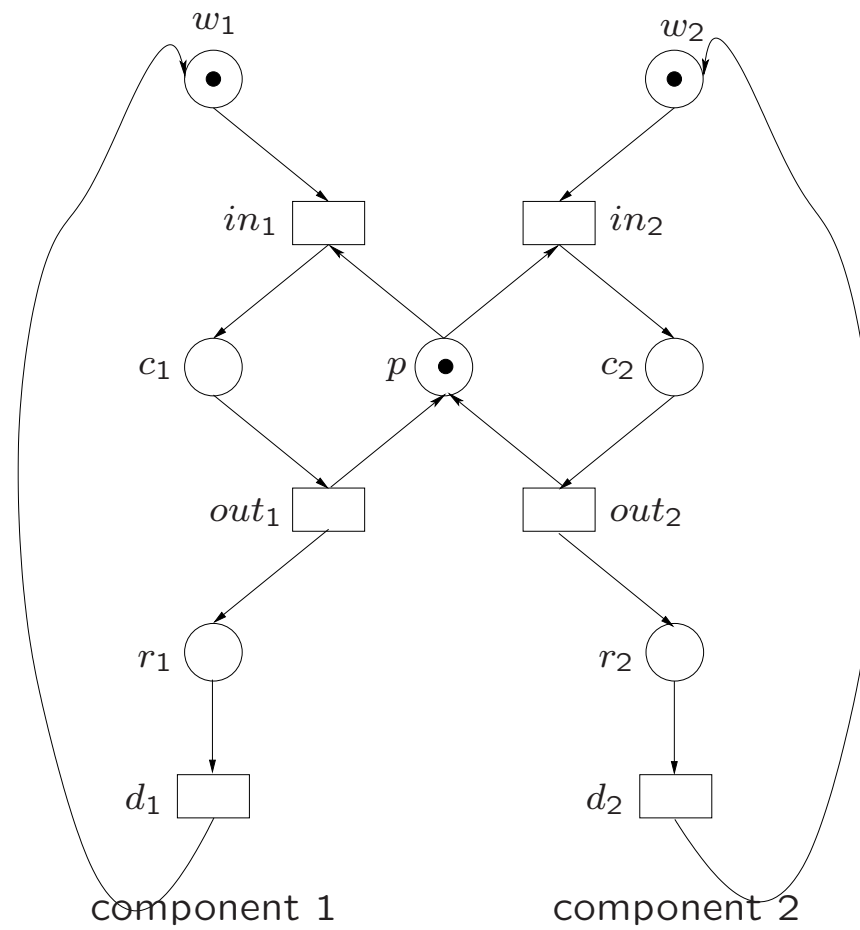

Fig. 5. The mutual exclusion problem.

Theorem 61. Let $M = (P, T, F, C_{in})$ be an EN system.

M is contact-free and conflict-free

iff for all $C \in \mathbb{C}_M$ and all $U \subseteq T$ with $U \neq \emptyset$,

if $\bullet U \subseteq C$, then $U \text{ con } C$.

6. Processes

Definition 62. Let A be a finite set.

A binary relation $\rho \subseteq A \times A$ is a *partial order on A* if ρ is irreflexive and transitive;
 (A, ρ) is also called a *partially ordered set*.

A subset B of A is *linearly ordered* if
for all $a, b \in B$: $a \rho b$ or $b \rho a$ or $a = b$.

Definition 63. Let (A, ρ) be a partially ordered set.

Then $\mathbf{li}_\rho \subseteq A \times A$ and $\mathbf{co}_\rho \subseteq A \times A$
are the binary relations such that, for every $a, b \in A$,

(1) $a \mathbf{li}_\rho b$ iff $a \rho b$ or $b \rho a$ or $a = b$, and

(2) $a \mathbf{co}_\rho b$ iff $\neg a \rho b$ and $\neg b \rho a$.

\mathbf{li}_ρ is called the *line relation of ρ* and

\mathbf{co}_ρ is called the *concurrency relation of ρ* .

Lemma 64. Let (A, ρ) be a partially ordered set.
Then, for every $a, b \in A$,

(1) $a \text{ li}_\rho b$ or $a \text{ co}_\rho b$, and

(2) $(a \text{ li}_\rho b \text{ and } a \text{ co}_\rho b)$ iff $a = b$.

Definition 65. Let A be a finite set, let $\sigma \subseteq A \times A$ be a reflexive symmetric relation, and let $B \subseteq A$.

B is a σ -clique if
 $a \sigma b$ for all $a, b \in B$, and

B is a *maximal* σ -clique if
 B is a σ -clique and
for every $a \in A - B$ there exists $b \in B$ such that $\neg a \sigma b$.

Lemma 66. Let A be a finite set and let $\sigma \subseteq A \times A$ be a reflexive symmetric relation.

For every σ -clique B there exists a maximal σ -clique C with $B \subseteq C$.

Definition 67. Let (A, ρ) be a partially ordered set.

A maximal li_ρ -clique is a *line of* ρ and

a maximal co_ρ -clique is a *cut of* ρ .

Definition 68. Let (A, ρ) be a partially ordered set.

The ordering ρ is *dense* if every line and every cut of ρ have a nonempty intersection.

Definition 69. Let (A, ρ) be a partially ordered set and let $B \subseteq A$. Then

$$(\rightarrow B)_\rho = \{a \in A \mid \exists b \in B : a \rho b \text{ or } a = b\},$$

$$(B \rightarrow)_\rho = \{a \in A \mid \exists b \in B : b \rho a \text{ or } b = a\},$$

$$({}^\circ B)_\rho = \{b \in B \mid \neg \exists b' \in B : b' \rho b\}, \text{ and}$$

$$(B^\circ)_\rho = \{b \in B \mid \neg \exists b' \in B : b \rho b'\}.$$

Lemma 70. Let (A, ρ) be a partially ordered set and let $B \subseteq A$.

Then $B \subseteq (\circ B)^{\rightarrow}$ and $B \subseteq \rightarrow(B^{\circ})$.

Theorem 71. Let (A, ρ) be a partially ordered set and let B be a cut of ρ .

(1) $\circ A$ and A° are cuts of ρ ,

(2) $(\circ A)^{\rightarrow} = A$, $\rightarrow(\circ A) = \circ A$, $(A^{\circ})^{\rightarrow} = A^{\circ}$, and $\rightarrow(A^{\circ}) = A$,

(3) $\rightarrow B \cup B^{\rightarrow} = A$ and $\rightarrow B \cap B^{\rightarrow} = B$,

(4) $\circ(\rightarrow B) = \circ A$, $(\rightarrow B)^{\circ} = B$, $\circ(B^{\rightarrow}) = B$, and $(B^{\rightarrow})^{\circ} = A^{\circ}$.

Lemma 70. Let (A, ρ) be a partially ordered set and let $B \subseteq A$.

Then $B \subseteq (\circ B)^{\rightarrow}$ and $B \subseteq \rightarrow(B^{\circ})$.

Lemma 72. Let (A, ρ) be a partially ordered set with $A \neq \emptyset$ and let L be a line of ρ . Then

$L \cap \circ A \neq \emptyset$ and $L \cap A^{\circ} \neq \emptyset$.

Definition 73. A net $N = (P, T, F)$ is a *process net* if:

(1) N is acyclic, and

(2) $\#(\bullet p) \leq 1$ and $\#(p\bullet) \leq 1$ for all $p \in P$.

Lemma 74. For every process net N ,
 F_N^+ is a partial order on X_N .